

SR-200-38A

JOINT WIDTH		MOVEMENT ±			
		MINIMUM		MAXIMUM	
US	mm	US	mm	US	mm
2"	51	1"	25	3"	75

*A/E AND CONTRACTOR TO VERIFY COMPATIBILITY OF COUNTERFLASHING WITH DECK MEMBRANE BEFORE ORDERING

FINISH: MILL
PROJECT:
CUSTOMER:
LOCATION:

APPLICATION- EXTERIOR COMPRESSION SEAL W/ ALUM. FRAMES

DATE:	7/18/17
SCALE:	1:2
DOC:	CADJM.190/R3



For More Information Visit: Inprocorp.com

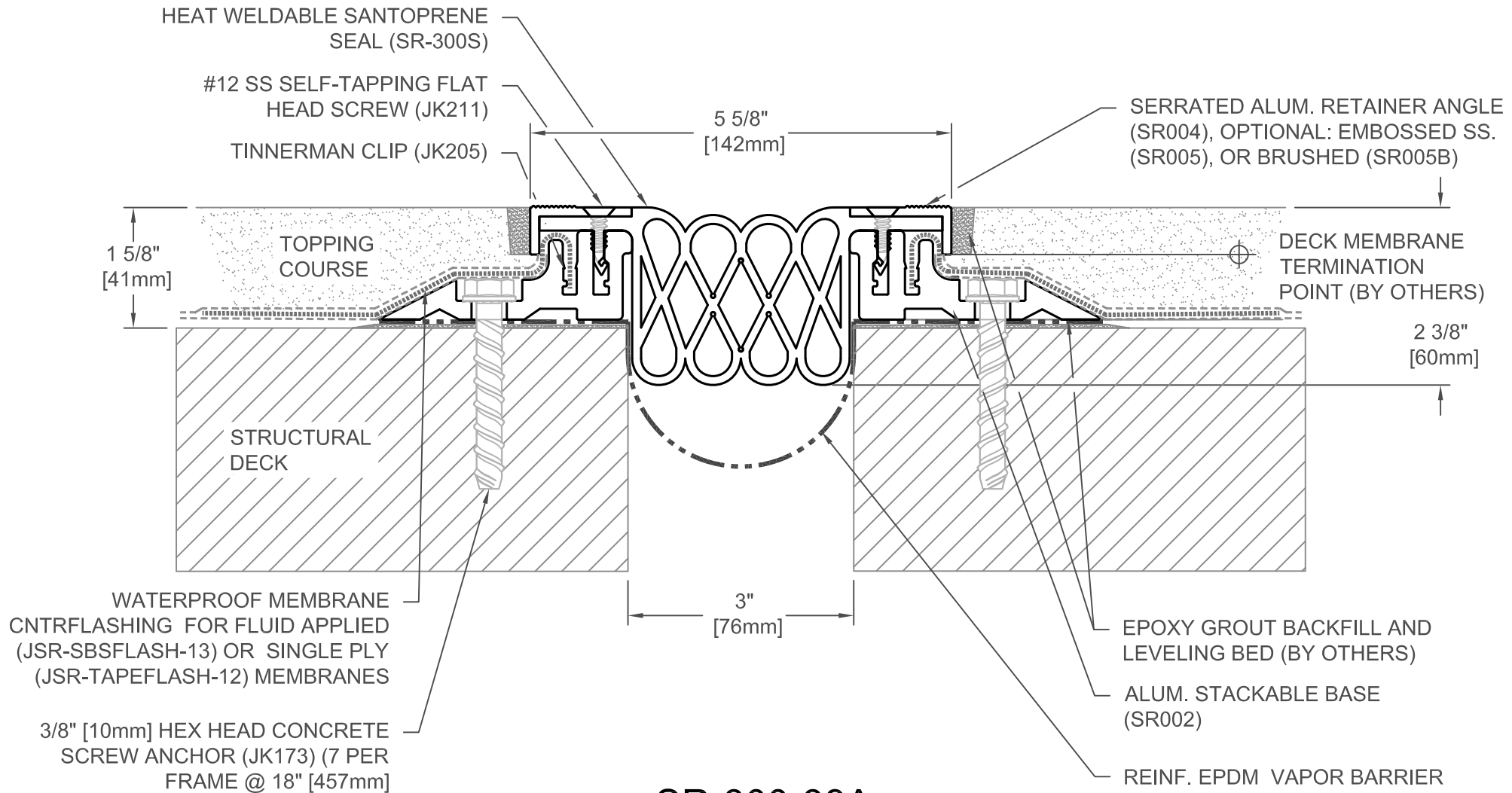

SR-300-38A

*A/E AND CONTRACTOR TO VERIFY COMPATIBILITY OF COUNTERFLASHING WITH DECK MEMBRANE BEFORE ORDERING

JOINT WIDTH		MOVEMENT ±			
		MINIMUM		MAXIMUM	
US	mm	US	mm	US	mm
3"	76	1 1/2"	38	4 1/2"	114

FINISH: MILL
PROJECT:
CUSTOMER:
LOCATION:

APPLICATION- EXTERIOR COMPRESSION SEAL W/ ALUM. FRAMES

DATE:	7/18/17
SCALE:	1:2
DOC:	CADJM.190/R3



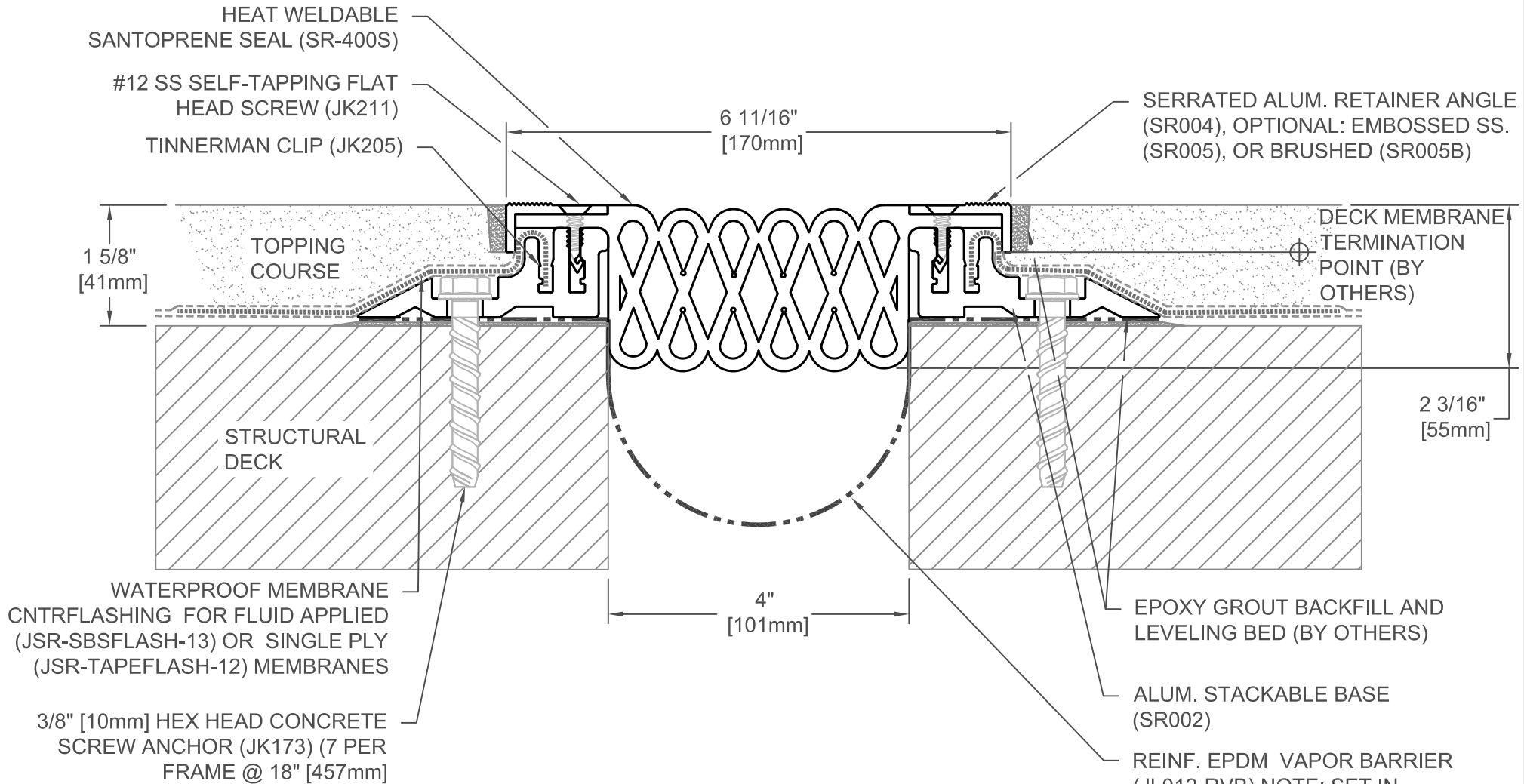

SR-400-38A

JOINT WIDTH		MOVEMENT ±			
		MINIMUM		MAXIMUM	
US	mm	US	mm	US	mm
4"	102	2"	51	6"	152

*A/E AND CONTRACTOR TO VERIFY COMPATIBILITY OF COUNTERFLASHING WITH DECK MEMBRANE BEFORE ORDERING

EPOXY GROUT BACKFILL AND LEVELING BED (BY OTHERS)

ALUM. STACKABLE BASE (SR002)

REINF. EPDM VAPOR BARRIER (JL012-RVB) NOTE: SET IN CONT. BED OF BUTYL SEALANT (BY OTHERS) TERMINATE RVB AT OUTSIDE EDGES OF SYSTEM

FINISH: MILL
PROJECT:
CUSTOMER:
LOCATION:

APPLICATION- EXTERIOR COMPRESSION SEAL W/ ALUM. FRAMES

DATE:	7/18/17
SCALE:	1:2
DOC:	CADJM.190/R3



For More Information Visit: Inprocorp.com

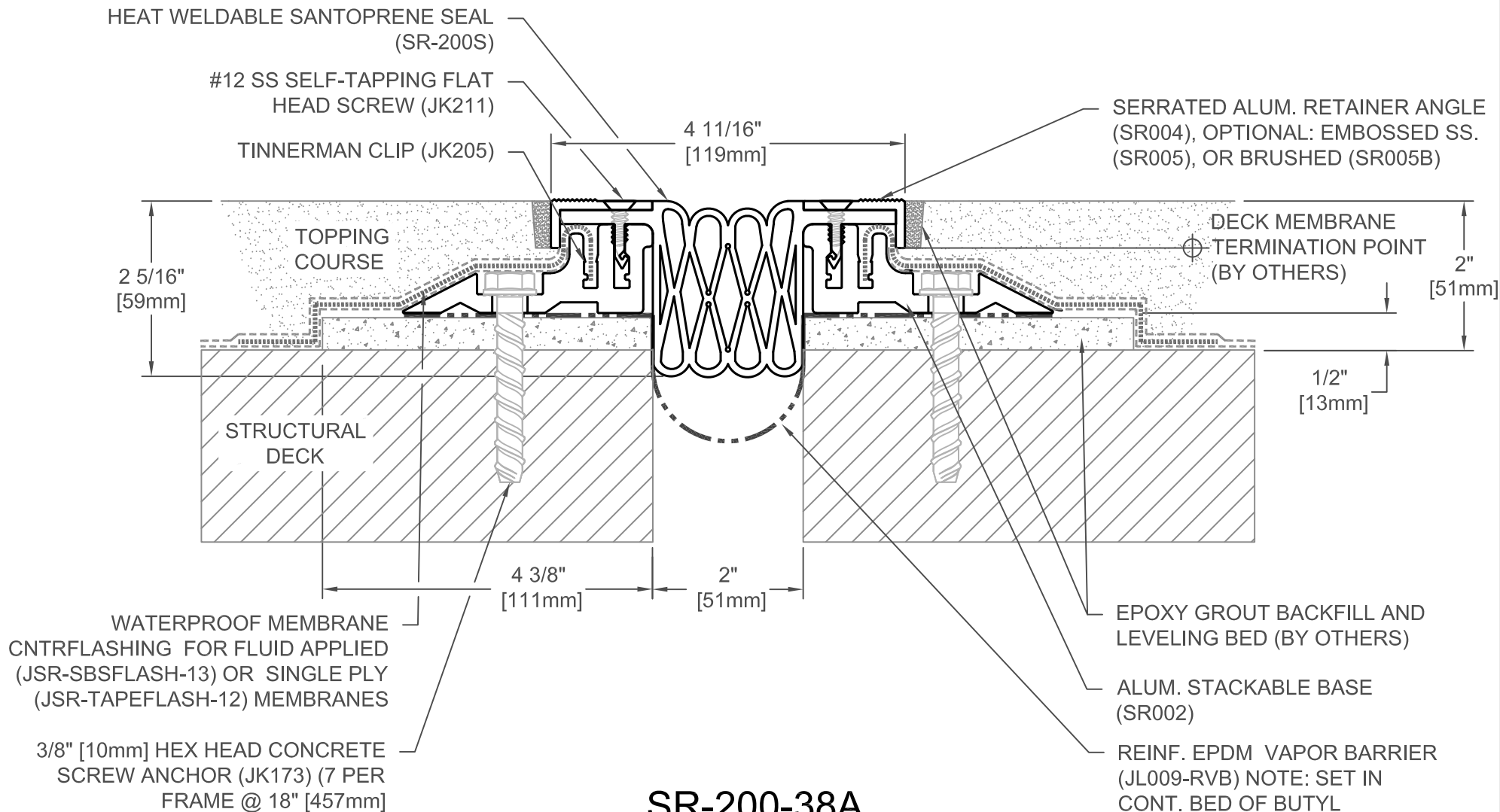

SR-200-38A

JOINT WIDTH		MOVEMENT ±			
		MINIMUM		MAXIMUM	
US	mm	US	mm	US	mm
2"	51	1"	25	3"	75

*A/E AND CONTRACTOR TO VERIFY COMPATIBILITY OF COUNTERFLASHING WITH DECK MEMBRANE BEFORE ORDERING

FINISH: MILL
PROJECT:
CUSTOMER:
LOCATION:

APPLICATION- EXTERIOR COMPRESSION SEAL W/ ALUM. FRAMES

DATE:	7/18/17
SCALE:	1:2
DOC:	CADJM.190/R3



For More Information Visit: Inprocorp.com

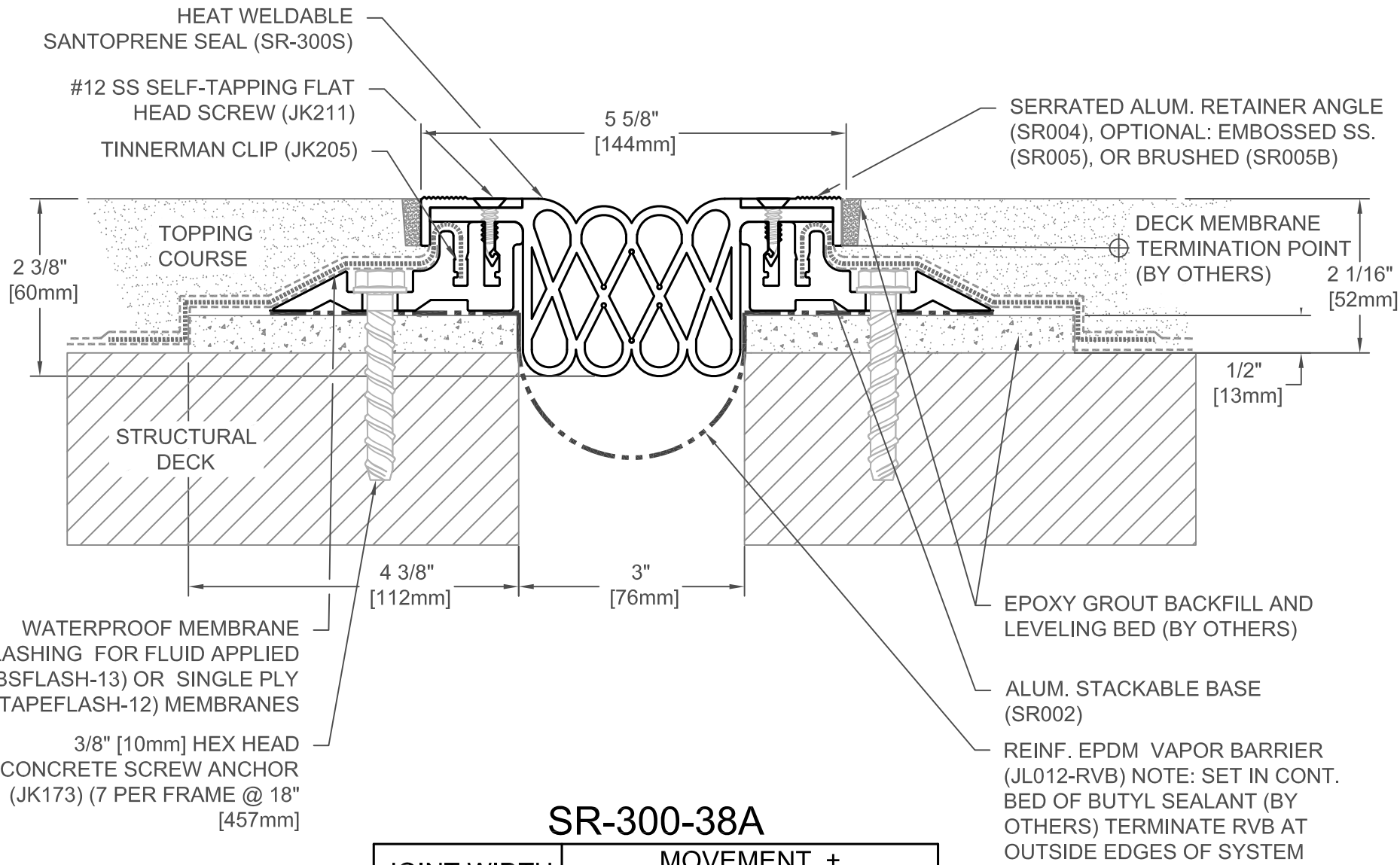

SR-300-38A

JOINT WIDTH		MOVEMENT ±			
		MINIMUM		MAXIMUM	
US	mm	US	mm	US	mm
3"	76	1 1/2"	38	4 1/2"	114

*A/E AND CONTRACTOR TO VERIFY COMPATIBILITY OF COUNTERFLASHING WITH DECK MEMBRANE BEFORE ORDERING

FINISH: MILL
PROJECT:
CUSTOMER:
LOCATION:

APPLICATION- EXTERIOR COMPRESSION SEAL W/ ALUM. FRAMES

DATE:	7/18/17
SCALE:	1:2
DOC:	CADJM.190/R3



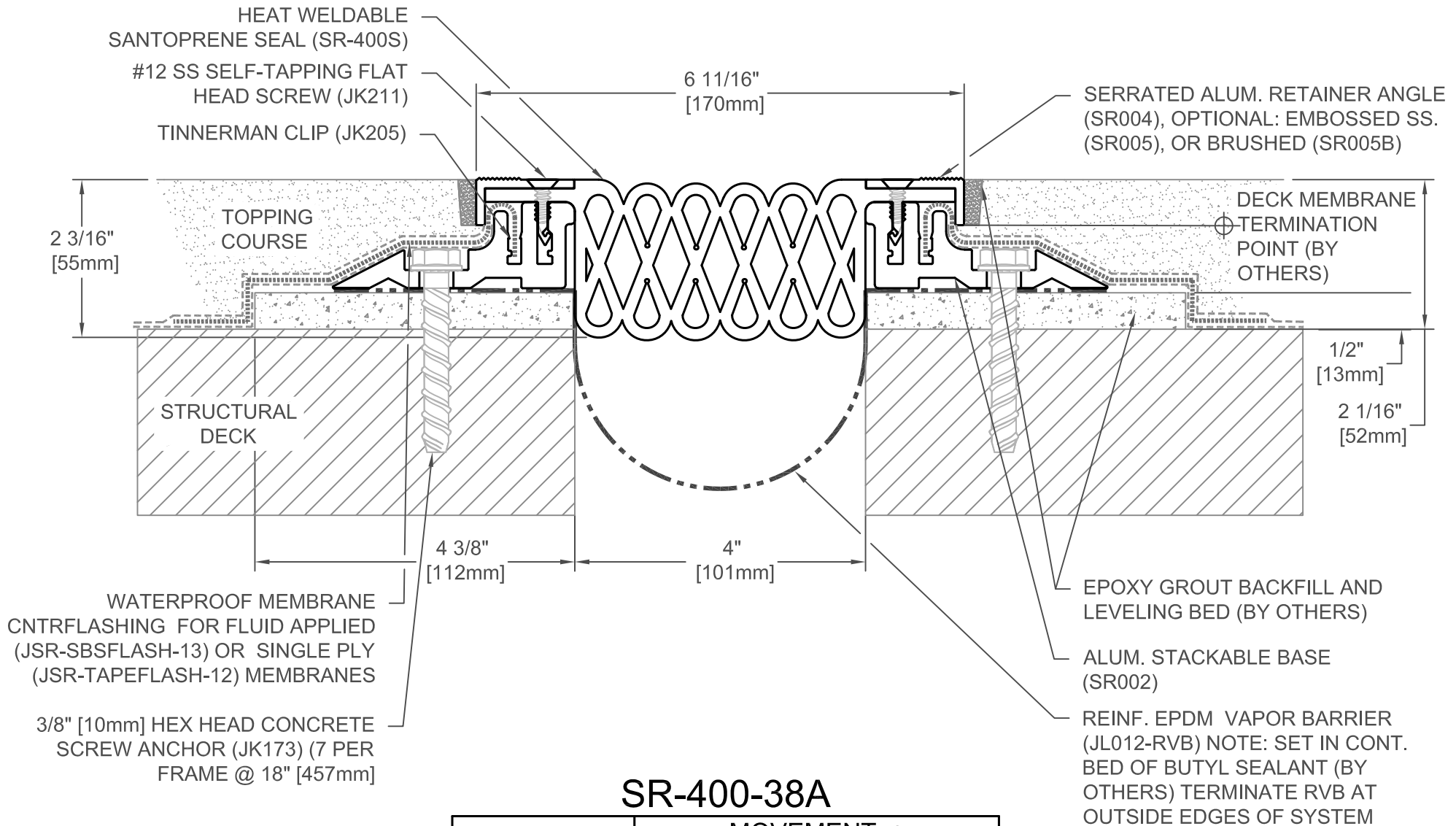

SR-400-38A

JOINT WIDTH		MOVEMENT ±			
		MINIMUM		MAXIMUM	
US	mm	US	mm	US	mm
4"	102	2"	51	6"	152

*A/E AND CONTRACTOR TO VERIFY COMPATIBILITY OF COUNTERFLASHING WITH DECK MEMBRANE BEFORE ORDERING

FINISH: MILL
PROJECT:
CUSTOMER:
LOCATION:

APPLICATION- EXTERIOR COMPRESSION SEAL W/ ALUM. FRAMES

DATE:	7/18/17
SCALE:	1:2
DOC:	CADJM.190/R3



For More Information Visit: Inprocorp.com

HEAT WELDABLE SANTOPRENE SEAL (SR-200S)
 #12 SS SELF-TAPPING FLAT HEAD SCREW (JK211)
 ALUM. STACKABLE FRAME (SR003)
 TINNERMAN CLIP (JK205)

SERRATED ALUM. RETAINER ANGLE (SR004), OPTIONAL: EMBOSSED SS. (SR005), OR BRUSHED (SR005B)

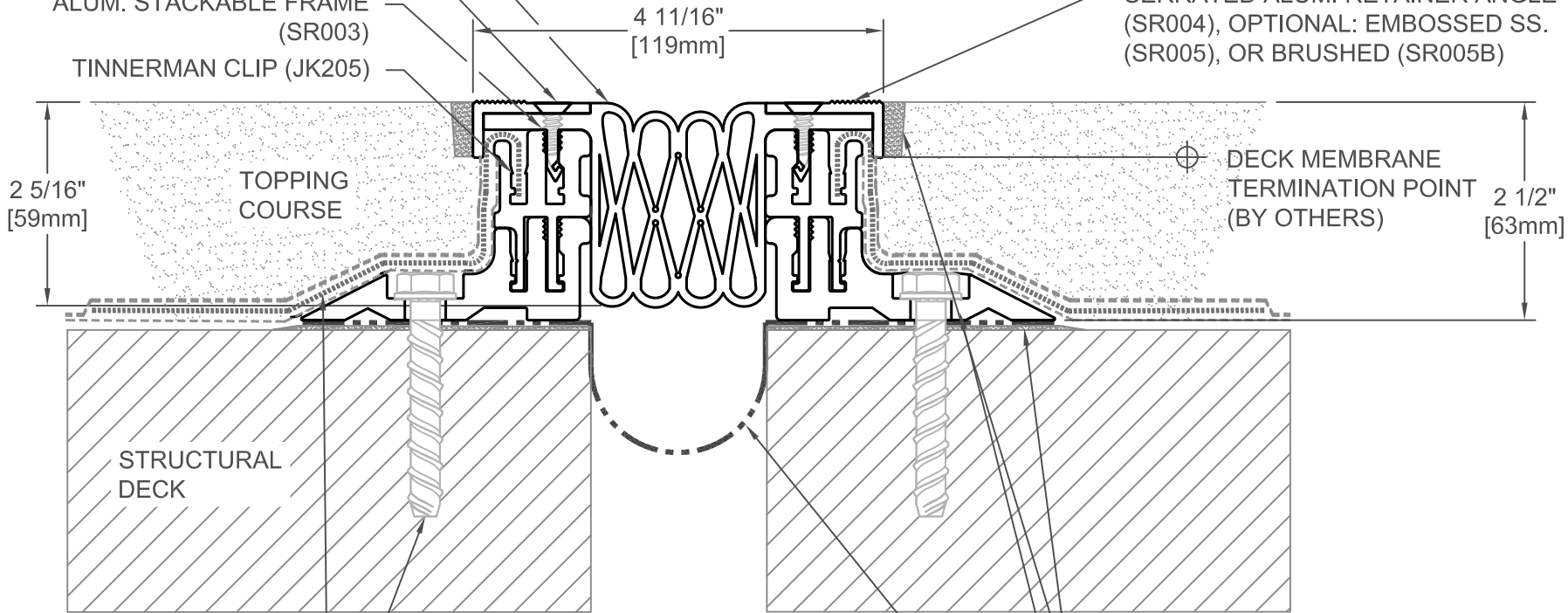

WATERPROOF MEMBRANE CNTRFLASHING FOR FLUID APPLIED (JSR-SBSFLASH-13) OR SINGLE PLY (JSR-TAPEFLASH-12) MEMBRANES
 3/8" [10mm] HEX HEAD CONCRETE SCREW ANCHOR (JK173) (7 PER FRAME @ 18" [457mm])

EPOXY GROUT BACKFILL AND LEVELING BED (BY OTHERS)
 ALUM. STACKABLE BASE (SR002)

REINF. EPDM VAPOR BARRIER (JL009-RVB) NOTE: SET IN CONT. BED OF BUTYL SEALANT (BY OTHERS) TERMINATE RVB AT OUTSIDE EDGES OF SYSTEM

SR-200-63A

JOINT WIDTH		MOVEMENT ±			
		MINIMUM		MAXIMUM	
US	mm	US	mm	US	mm
2"	51	1"	25	3"	75

*A/E AND CONTRACTOR TO VERIFY COMPATIBILITY OF COUNTERFLASHING WITH DECK MEMBRANE BEFORE ORDERING

FINISH: MILL
PROJECT:
CUSTOMER:
LOCATION:

APPLICATION- EXTERIOR COMPRESSION SEAL W/ ALUM. FRAMES

DATE:	7/18/17
SCALE:	1:2
DOC:	CADJM.190/R3



HEAT WELDABLE SANTOPRENE SEAL (SR-300S)
 #12 SS SELF-TAPPING FLAT HEAD SCREW (JK211)
 ALUM. STACKABLE FRAME (SR003)
 TINNERMAN CLIP (JK205)

SERRATED ALUM. RETAINER ANGLE (SR004), OPTIONAL: EMBOSSED SS. (SR005), OR BRUSHED (SR005B)

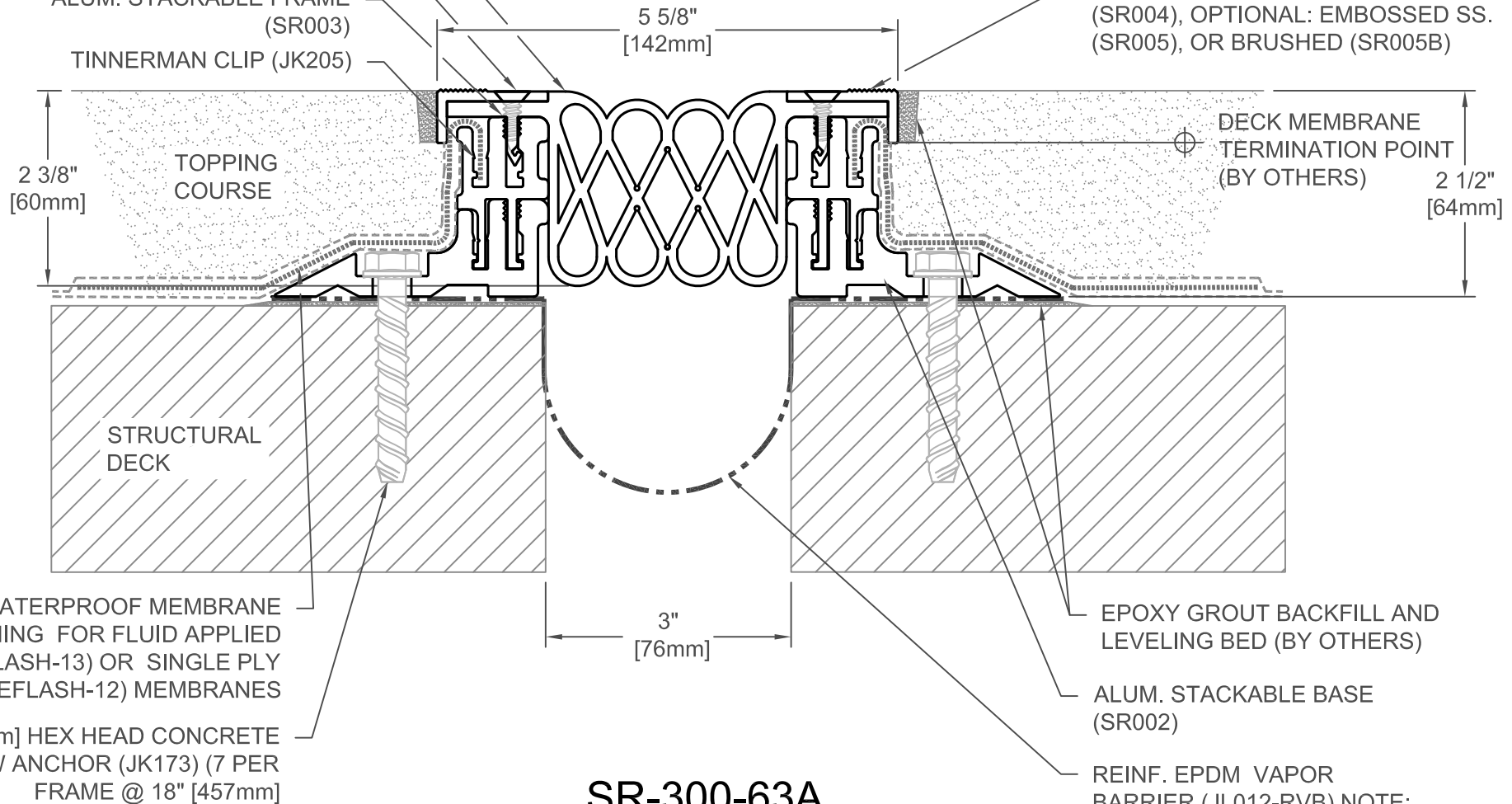

TOPPING COURSE
 2 3/8" [60mm]
 STRUCTURAL DECK
 WATERPROOF MEMBRANE CNTRFLASHING FOR FLUID APPLIED (JSR-SBSFLASH-13) OR SINGLE PLY (JSR-TAPEFLASH-12) MEMBRANES
 3/8" [10mm] HEX HEAD CONCRETE SCREW ANCHOR (JK173) (7 PER FRAME @ 18" [457mm])

DECK MEMBRANE TERMINATION POINT (BY OTHERS)
 2 1/2" [64mm]
 EPOXY GROUT BACKFILL AND LEVELING BED (BY OTHERS)
 ALUM. STACKABLE BASE (SR002)
 REINF. EPDM VAPOR BARRIER (JL012-RVB) NOTE: SET IN CONT. BED OF BUTYL SEALANT (BY OTHERS) TERMINATE RVB AT OUTSIDE EDGES OF SYSTEM

SR-300-63A

JOINT WIDTH		MOVEMENT ±			
US	mm	MINIMUM	MAXIMUM	MINIMUM	MAXIMUM
US	mm	US	mm	US	mm
3"	76	1 1/2"	38	4 1/2"	114

*A/E AND CONTRACTOR TO VERIFY COMPATIBILITY OF COUNTERFLASHING WITH DECK MEMBRANE BEFORE ORDERING

FINISH: MILL
PROJECT:
CUSTOMER:
LOCATION:

APPLICATION- EXTERIOR COMPRESSION SEAL W/ ALUM. FRAMES

DATE: 7/18/17
 SCALE: 1:2
 DOC: CADJM.190/R3



For More Information Visit: Inprocorp.com

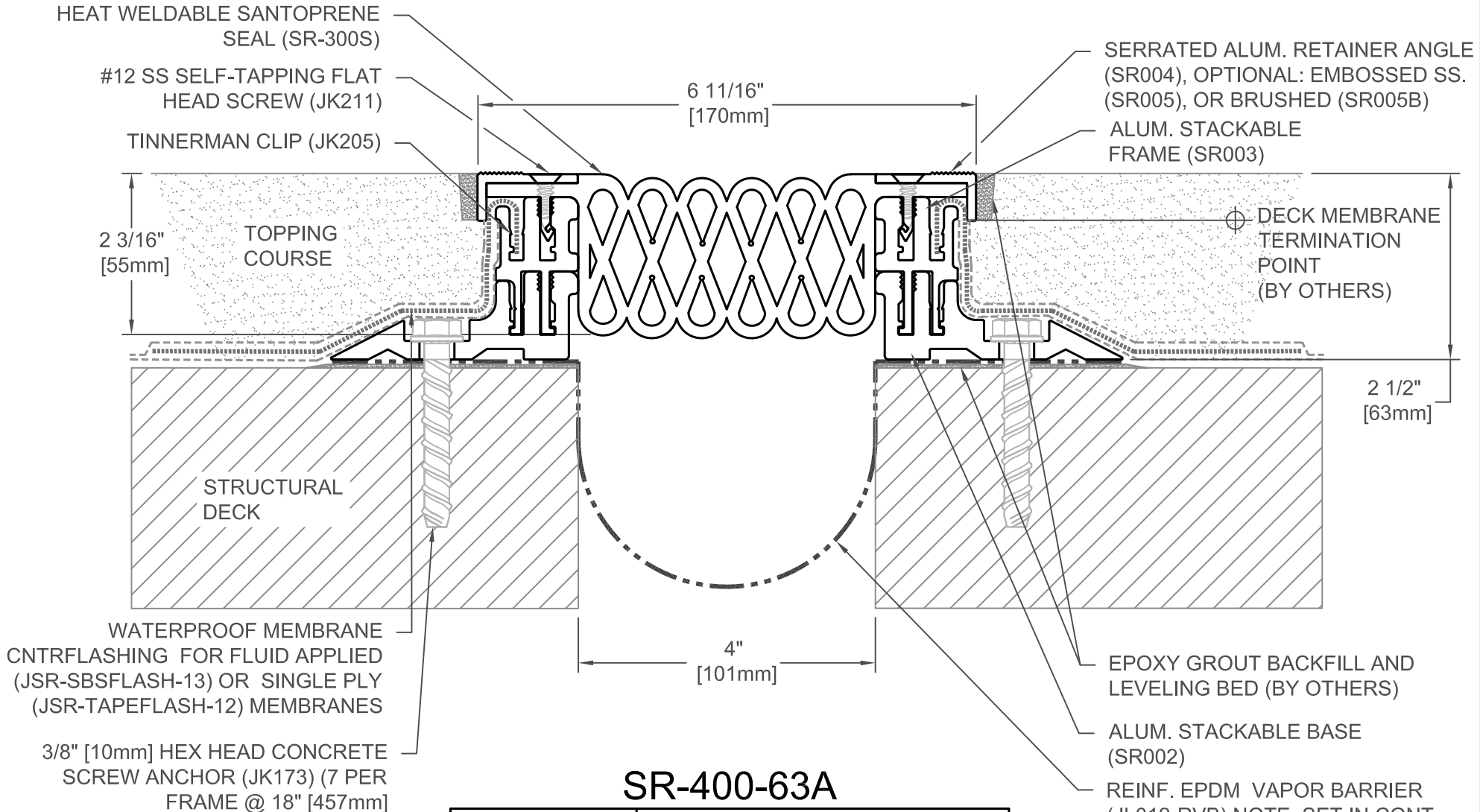

SR-400-63A

JOINT WIDTH		MOVEMENT ±			
		MINIMUM		MAXIMUM	
US	mm	US	mm	US	mm
4"	102	2"	51	6"	152

*A/E AND CONTRACTOR TO VERIFY COMPATIBILITY OF COUNTERFLASHING WITH DECK MEMBRANE BEFORE ORDERING

EPOXY GROUT BACKFILL AND LEVELING BED (BY OTHERS)
 ALUM. STACKABLE BASE (SR002)
 REINF. EPDM VAPOR BARRIER (JL012-RVB) NOTE: SET IN CONT. BED OF BUTYL SEALANT (BY OTHERS) TERMINATE RVB AT OUTSIDE EDGES OF SYSTEM

FINISH: MILL
PROJECT:
CUSTOMER:
LOCATION:

APPLICATION- EXTERIOR COMPRESSION SEAL W/ ALUM. FRAMES

DATE:	7/18/17
SCALE:	1:2
DOC:	CADJM.190/R3



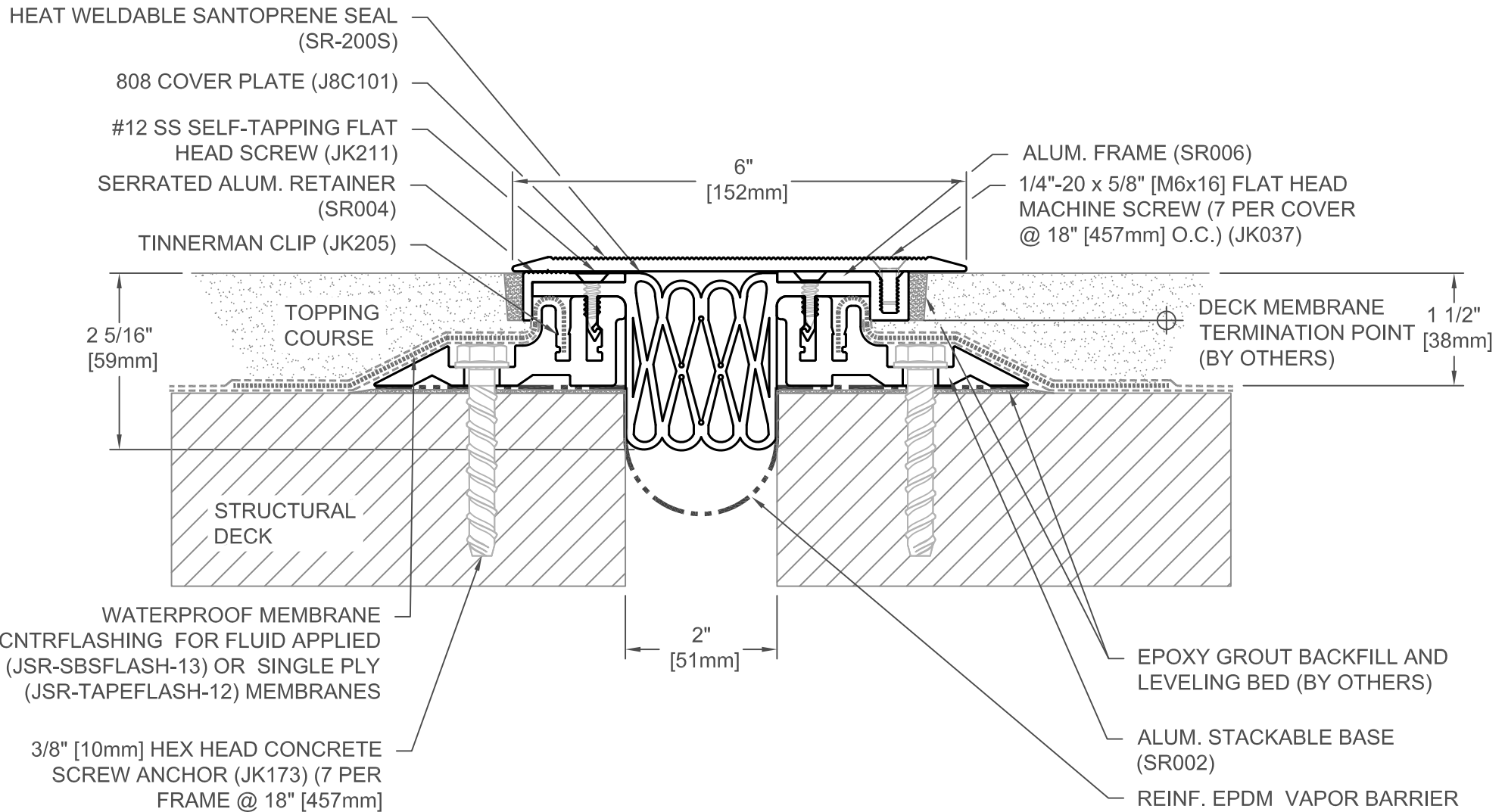

SR-200A-38A

JOINT WIDTH		MOVEMENT ±			
		MINIMUM		MAXIMUM	
US	mm	US	mm	US	mm
2"	51	1"	25	3"	75

*A/E AND CONTRACTOR TO VERIFY COMPATIBILITY OF COUNTERFLASHING WITH DECK MEMBRANE BEFORE ORDERING

FINISH: MILL
PROJECT:
CUSTOMER:
LOCATION:

APPLICATION- EXTERIOR COMPRESSION SEAL W/ ALUM. FRAMES

DATE:	7/18/17
SCALE:	1:2
DOC:	CADJM.190/R3



For More Information Visit: Inprocorp.com

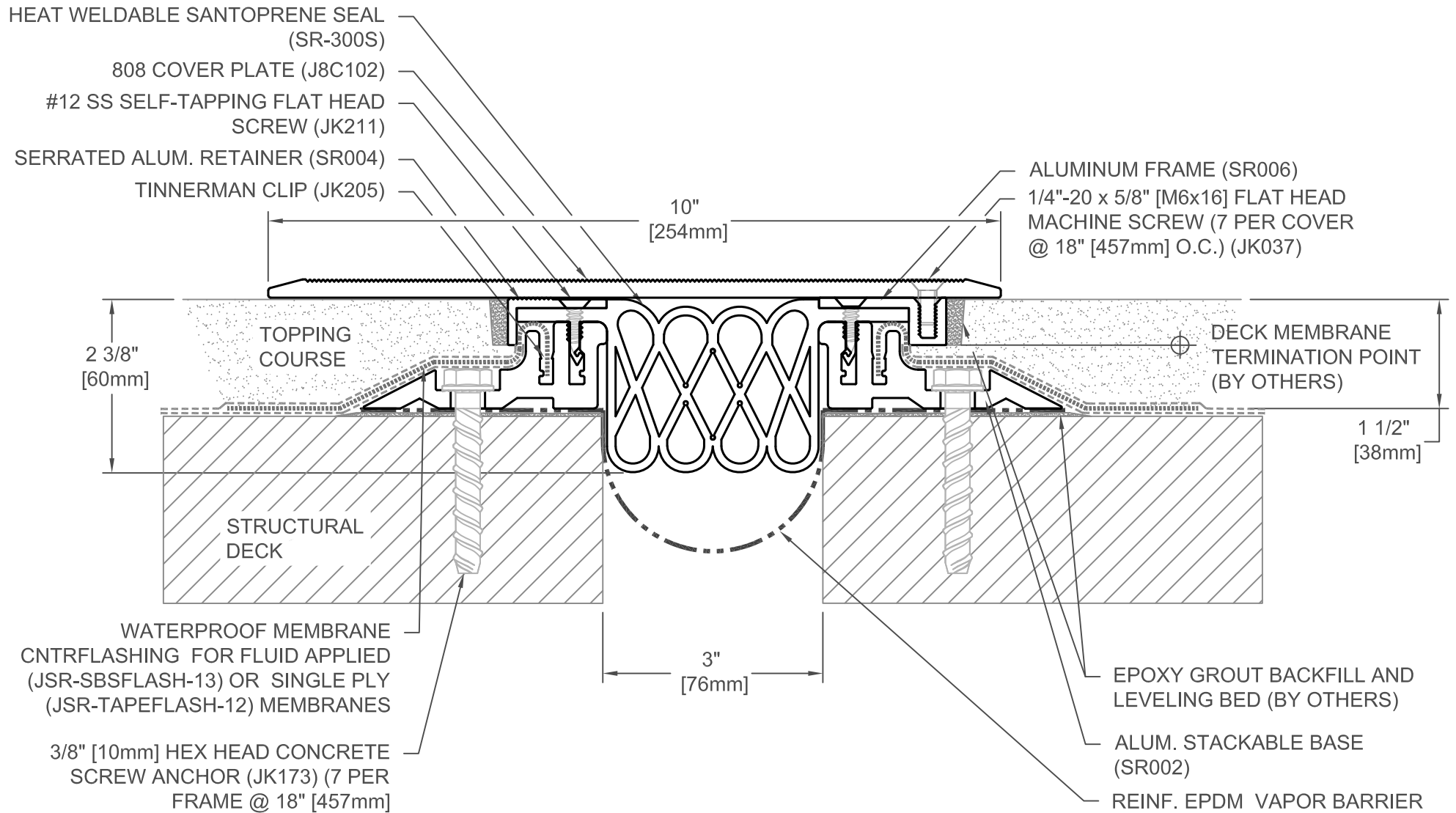

SR-300A-38A

JOINT WIDTH		MOVEMENT ±			
		MINIMUM		MAXIMUM	
US	mm	US	mm	US	mm
3"	76	1 1/2"	38	4 1/2"	114

*A/E AND CONTRACTOR TO VERIFY COMPATIBILITY OF COUNTERFLASHING WITH DECK MEMBRANE BEFORE ORDERING

FINISH: MILL
PROJECT:
CUSTOMER:
LOCATION:

APPLICATION- EXTERIOR COMPRESSION SEAL W/ ALUM. FRAMES

DATE:	7/18/17
SCALE:	1:2
DOC:	CADJM.190/R3



For More Information Visit: Inprocorp.com

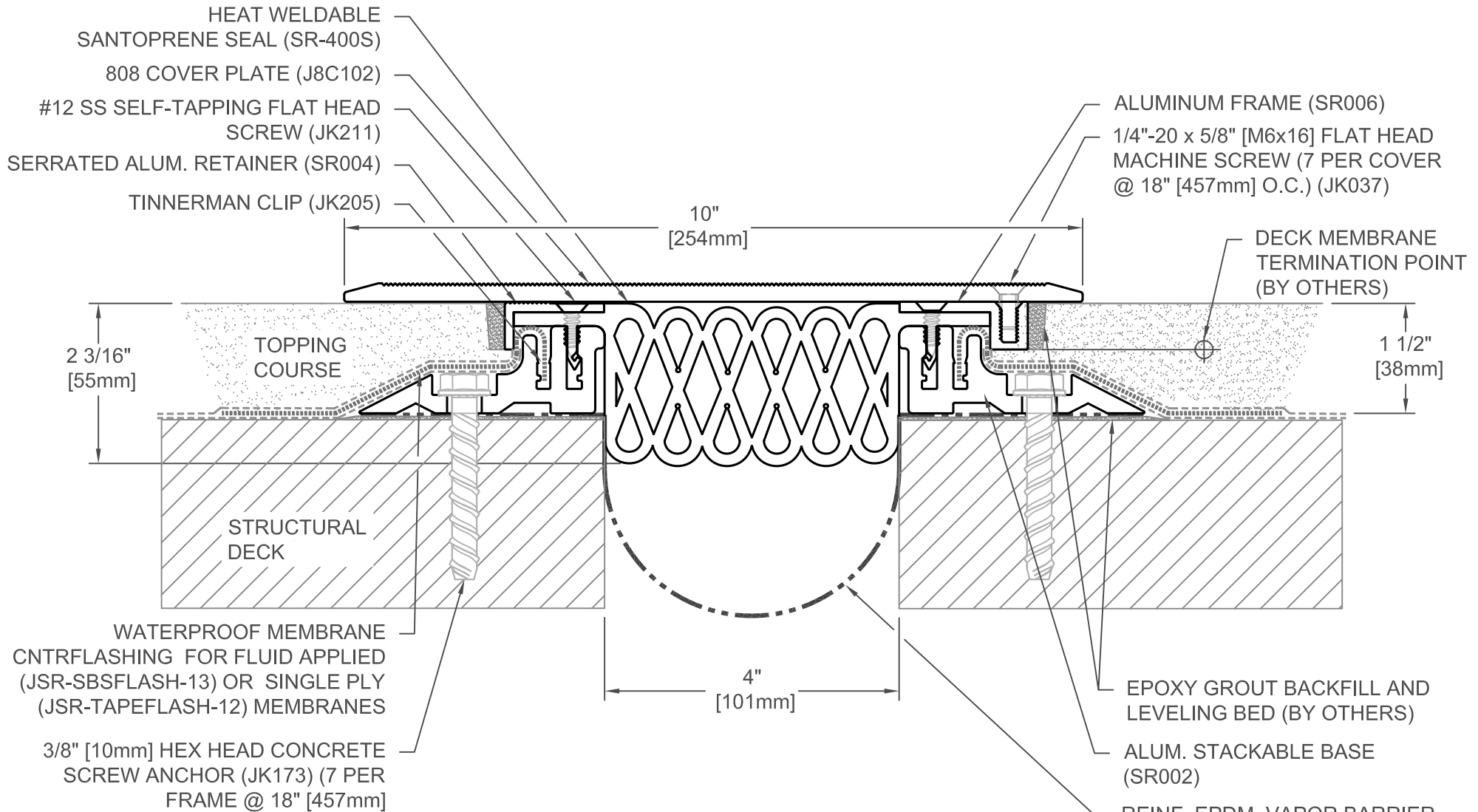

SR-400A-38A

JOINT WIDTH		MOVEMENT ±			
		MINIMUM		MAXIMUM	
US	mm	US	mm	US	mm
4"	102	2"	51	6"	152

*A/E AND CONTRACTOR TO VERIFY COMPATIBILITY OF COUNTERFLASHING WITH DECK MEMBRANE BEFORE ORDERING

FINISH: MILL
PROJECT:
CUSTOMER:
LOCATION:

APPLICATION- EXTERIOR COMPRESSION SEAL W/ ALUM. FRAMES

DATE:	7/18/17
SCALE:	1:2
DOC:	CADJM.190/R3



For More Information Visit: Inprocorp.com

HEAT WELDABLE SANTOPRENE SEAL (SR-200S)

808 COVER PLATE (J8C101)

#12 SS SELF-TAPPING FLAT HEAD SCREW (JK211)

SERRATED ALUM. RETAINER (SR004)

TINNERMAN CLIP (JK205)

ALUM. FRAME (SR006)

1/4"-20 x 5/8" [M6x16] FLAT HEAD MACHINE SCREW (7 PER COVER @ 18" [457mm] O.C.) (JK037)

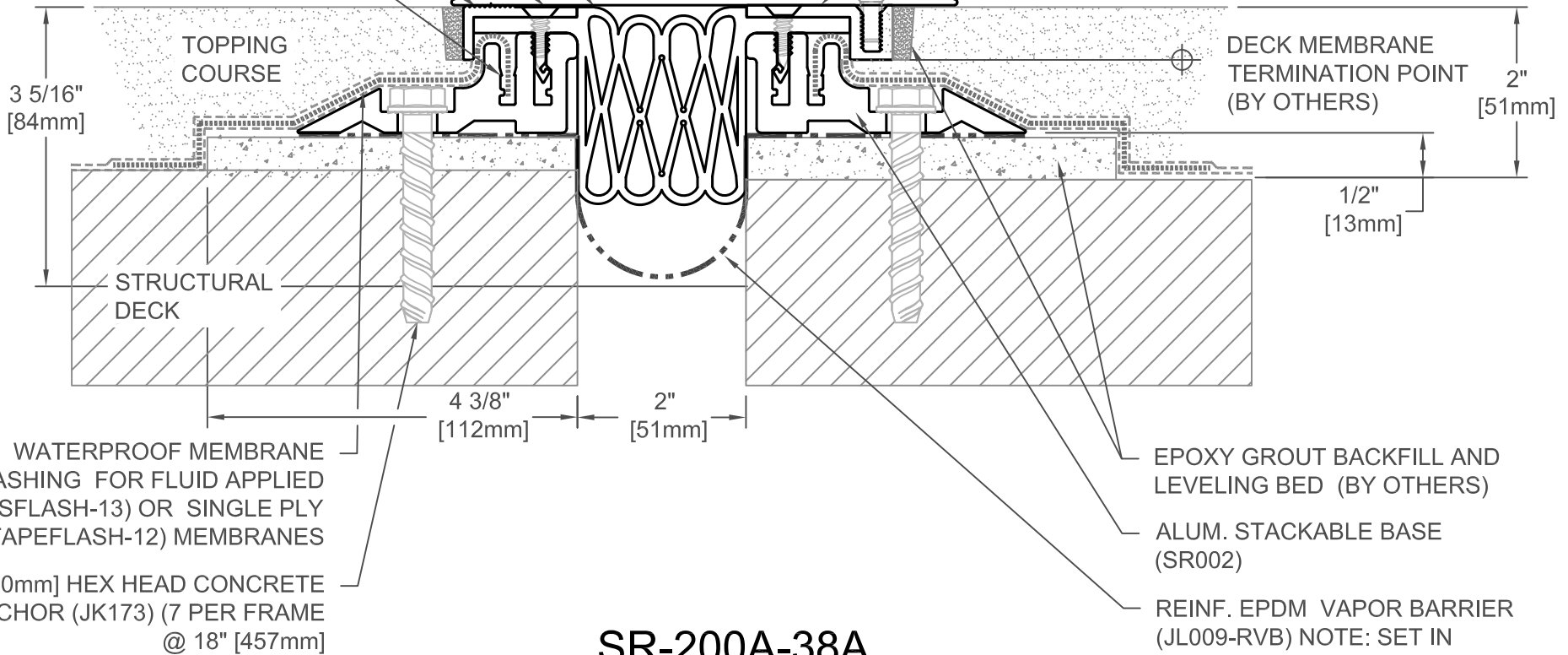

SR-200A-38A

JOINT WIDTH		MOVEMENT ±			
		MINIMUM		MAXIMUM	
US	mm	US	mm	US	mm
2"	51	1"	25	3"	75

*A/E AND CONTRACTOR TO VERIFY COMPATIBILITY OF COUNTERFLASHING WITH DECK MEMBRANE BEFORE ORDERING

EPOXY GROUT BACKFILL AND LEVELING BED (BY OTHERS)

ALUM. STACKABLE BASE (SR002)

REINF. EPDM VAPOR BARRIER (JL009-RVB) NOTE: SET IN CONT. BED OF BUTYL SEALANT (BY OTHERS) TERMINATE RVB AT OUTSIDE EDGES OF SYSTEM

FINISH: MILL
PROJECT:
CUSTOMER:
LOCATION:

APPLICATION- EXTERIOR COMPRESSION SEAL W/ ALUM. FRAMES

DATE:	7/18/17
SCALE:	1:2
DOC:	CADJM.190/R3



For More Information Visit: Inprocorp.com

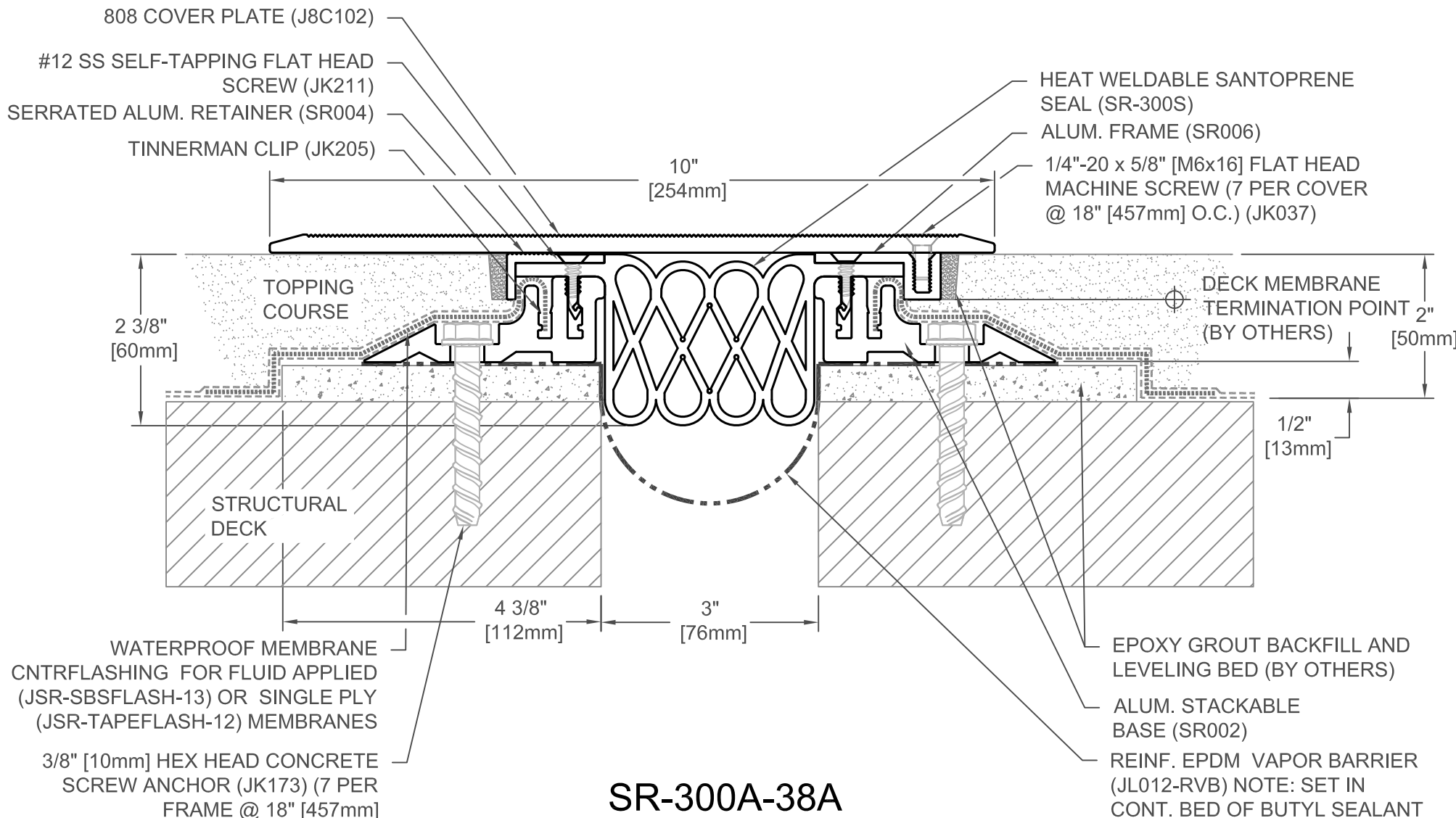

SR-300A-38A

JOINT WIDTH		MOVEMENT ±			
		MINIMUM		MAXIMUM	
US	mm	US	mm	US	mm
3"	76	1 1/2"	38	4 1/2"	114

*A/E AND CONTRACTOR TO VERIFY COMPATIBILITY OF COUNTERFLASHING WITH DECK MEMBRANE BEFORE ORDERING

FINISH: MILL

PROJECT:

CUSTOMER:

LOCATION:

APPLICATION- EXTERIOR COMPRESSION SEAL W/ ALUM. FRAMES

DATE: 7/18/17

SCALE: 1:2

DOC: CADJM.190/R3



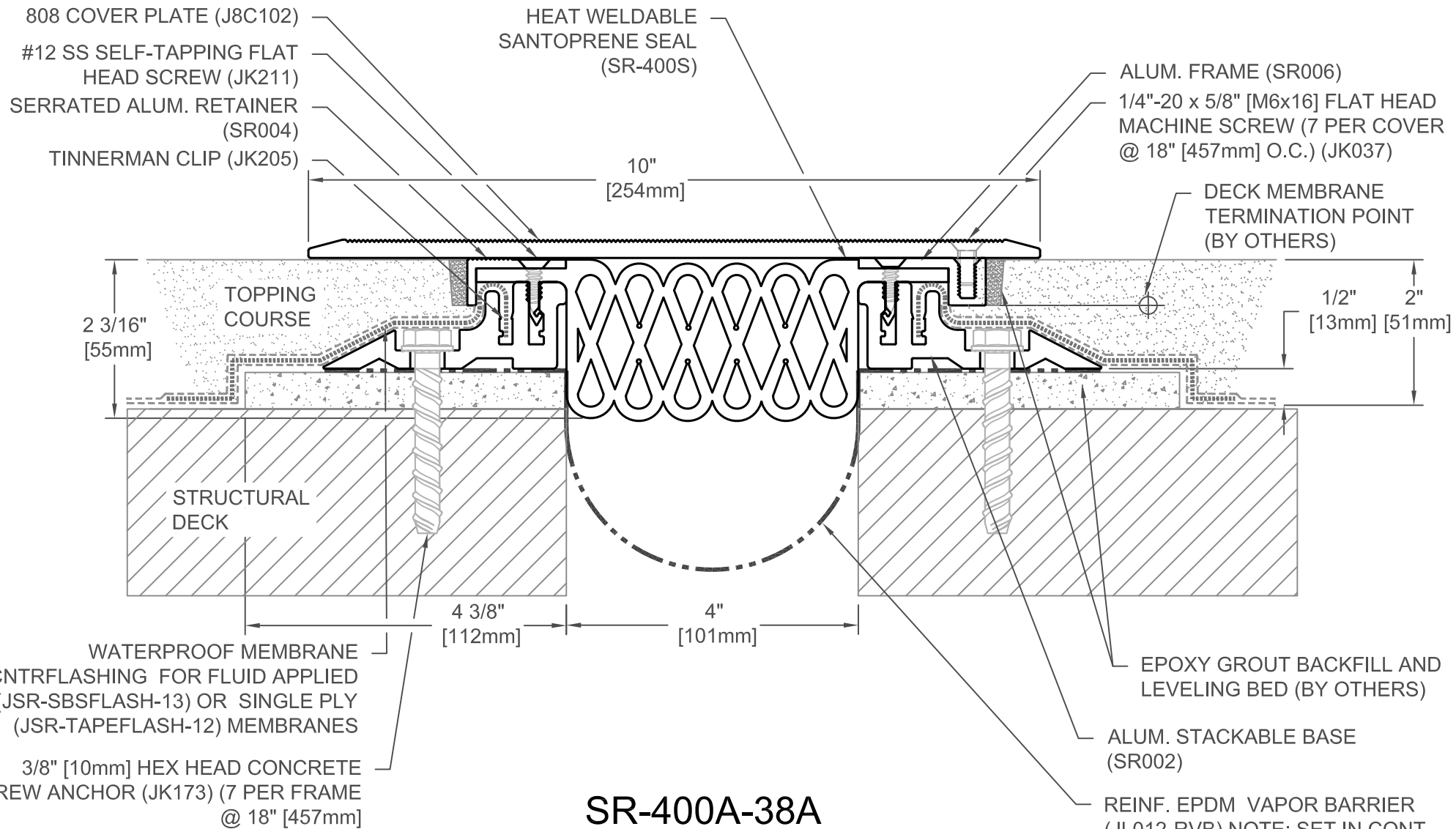

SR-400A-38A

JOINT WIDTH		MOVEMENT ±			
		MINIMUM		MAXIMUM	
US	mm	US	mm	US	mm
4"	102	2"	51	6"	152

*A/E AND CONTRACTOR TO VERIFY COMPATIBILITY OF COUNTERFLASHING WITH DECK MEMBRANE BEFORE ORDERING

FINISH: MILL
PROJECT:
CUSTOMER:
LOCATION:

APPLICATION- EXTERIOR COMPRESSION SEAL W/ ALUM. FRAMES

DATE:	7/18/17
SCALE:	1:2
DOC:	CADJM.190/R3



For More Information Visit: Inprocorp.com

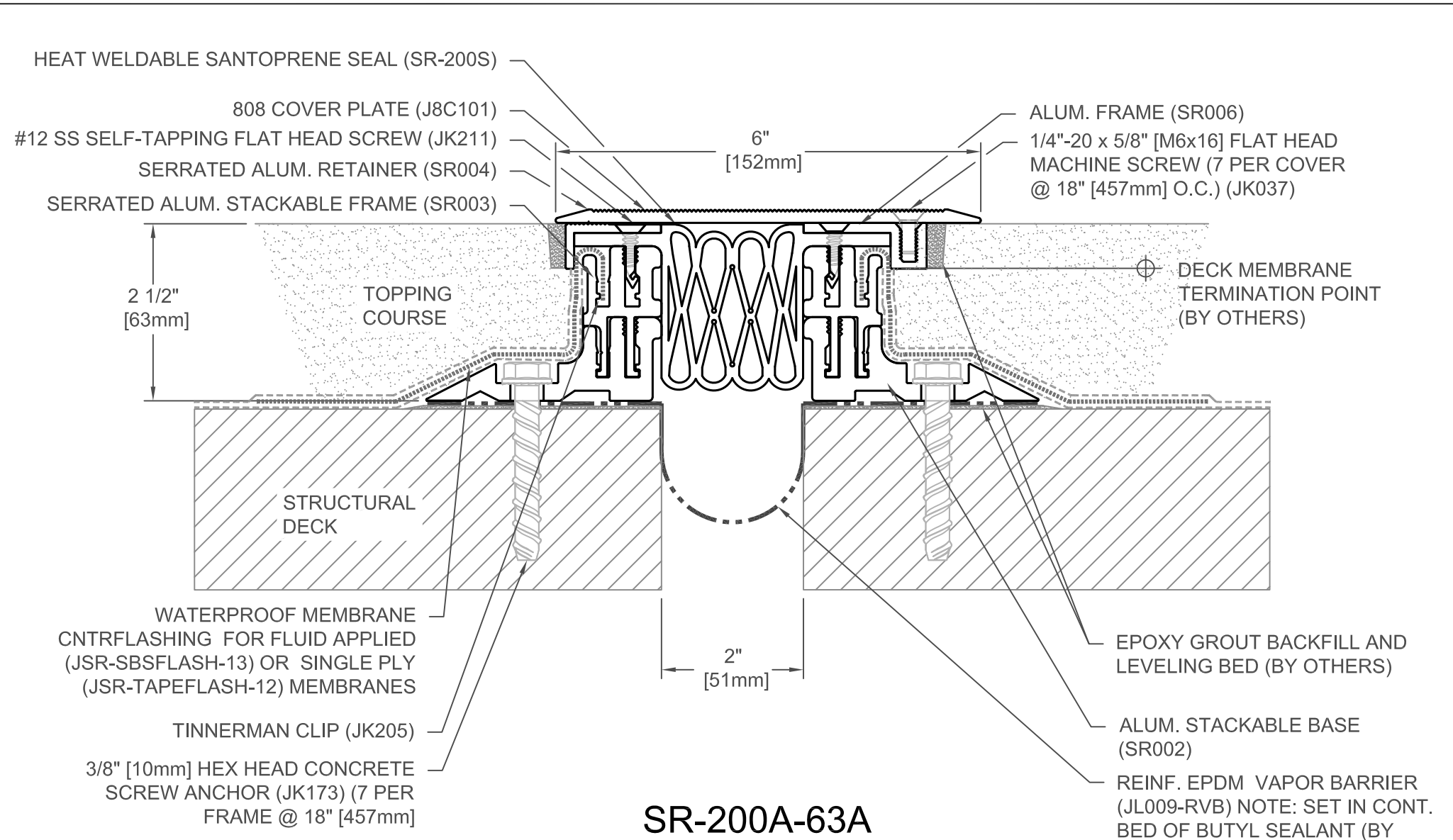

SR-200A-63A

JOINT WIDTH		MOVEMENT ±			
		MINIMUM		MAXIMUM	
US	mm	US	mm	US	mm
2"	51	1"	25	3"	75

*A/E AND CONTRACTOR TO VERIFY COMPATIBILITY OF COUNTERFLASHING WITH DECK MEMBRANE BEFORE ORDERING

EPOXY GROUT BACKFILL AND LEVELING BED (BY OTHERS)

ALUM. STACKABLE BASE (SR002)

REINF. EPDM VAPOR BARRIER (JL009-RVB) NOTE: SET IN CONT. BED OF BUTYL SEALANT (BY OTHERS) TERMINATE RVB AT OUTSIDE EDGES OF SYSTEM

FINISH: MILL
PROJECT:
CUSTOMER:
LOCATION:

APPLICATION- EXTERIOR COMPRESSION SEAL W/ ALUM. FRAMES

DATE:	7/18/17
SCALE:	1:2
DOC:	CADJM.190/R3



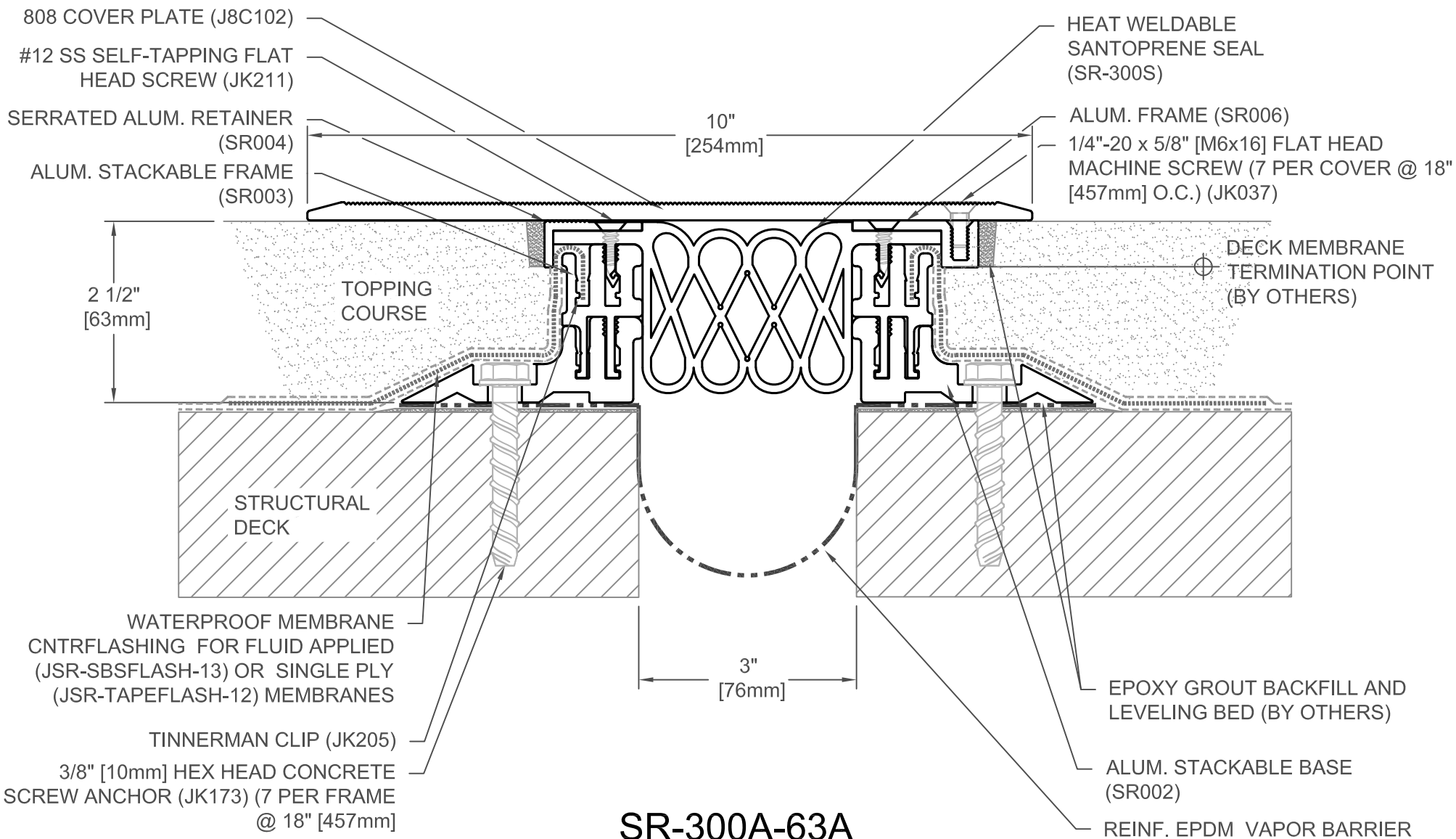

SR-300A-63A

JOINT WIDTH		MOVEMENT ±			
		MINIMUM		MAXIMUM	
US	mm	US	mm	US	mm
3"	76	1 1/2"	38	4 1/2"	114

*A/E AND CONTRACTOR TO VERIFY COMPATIBILITY OF COUNTERFLASHING WITH DECK MEMBRANE BEFORE ORDERING

EPOXY GROUT BACKFILL AND LEVELING BED (BY OTHERS)

ALUM. STACKABLE BASE (SR002)

REINF. EPDM VAPOR BARRIER (JL012-RVB) NOTE: SET IN CONT. BED OF BUTYL SEALANT (BY OTHERS) TERMINATE RVB AT OUTSIDE EDGES OF SYSTEM

FINISH: MILL
PROJECT:
CUSTOMER:
LOCATION:

APPLICATION- EXTERIOR COMPRESSION SEAL W/ ALUM. FRAMES

DATE:	7/18/17
SCALE:	1:2
DOC:	CADJM.190/R3



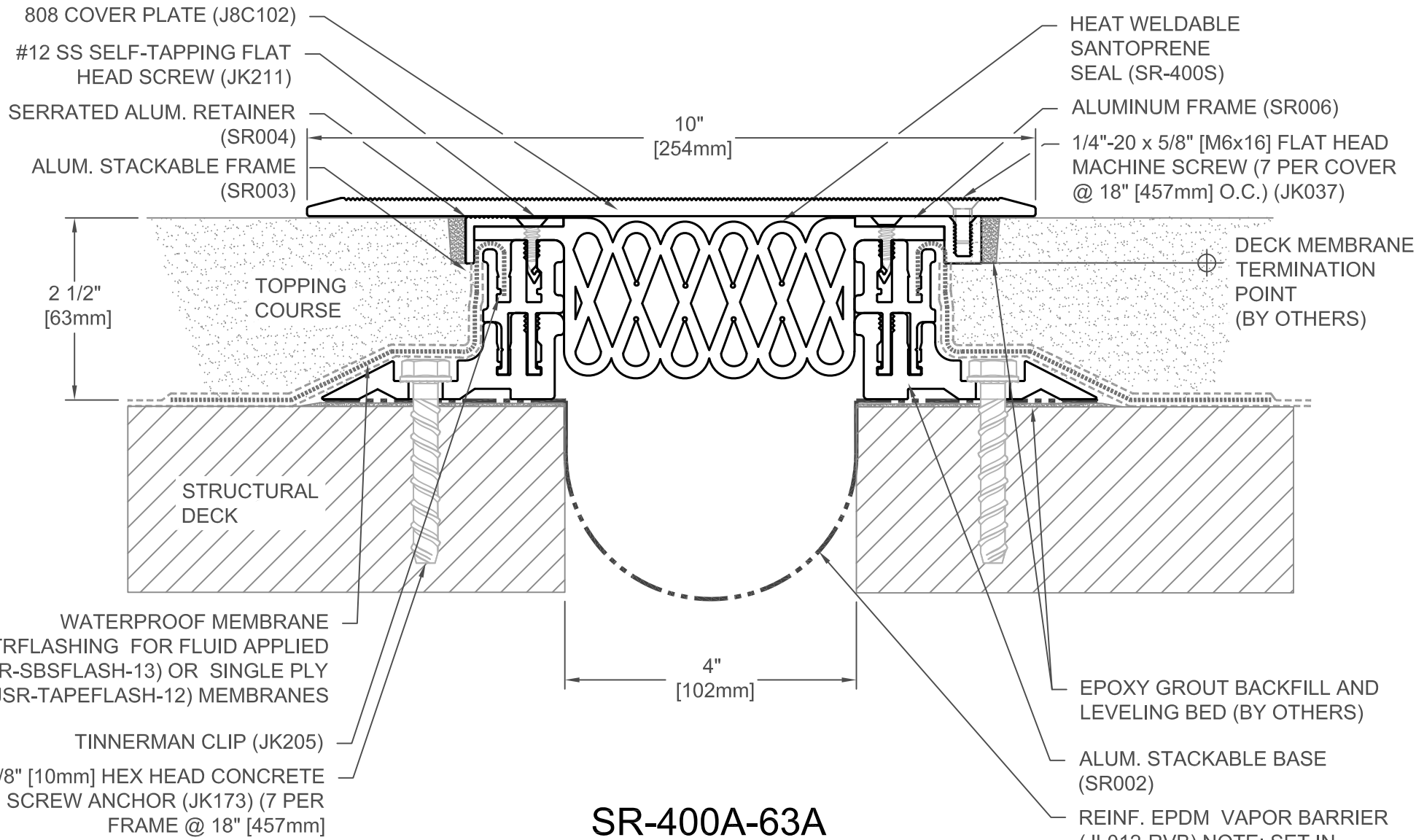

SR-400A-63A

JOINT WIDTH		MOVEMENT ±			
		MINIMUM		MAXIMUM	
US	mm	US	mm	US	mm
4"	102	2"	51	6"	152

*A/E AND CONTRACTOR TO VERIFY COMPATIBILITY OF COUNTERFLASHING WITH DECK MEMBRANE BEFORE ORDERING

EPOXY GROUT BACKFILL AND LEVELING BED (BY OTHERS)
 ALUM. STACKABLE BASE (SR002)
 REINF. EPDM VAPOR BARRIER (JL012-RVB) NOTE: SET IN CONT. BED OF BUTYL SEALANT (BY OTHERS) TERMINATE RVB AT OUTSIDE EDGES OF SYSTEM

FINISH: MILL
PROJECT:
CUSTOMER:
LOCATION:

APPLICATION- EXTERIOR COMPRESSION SEAL W/ ALUM. FRAMES

DATE:	7/18/17
SCALE:	1:2
DOC:	CADJM.190/R3

