

Stainless Steel Column Covers

Square Slide Lock & Square Slide Lock 3/4" Radius Column Cover

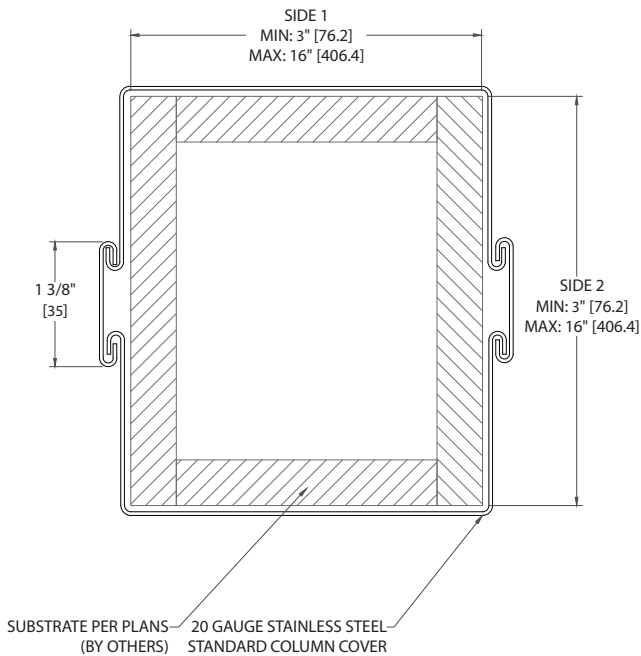
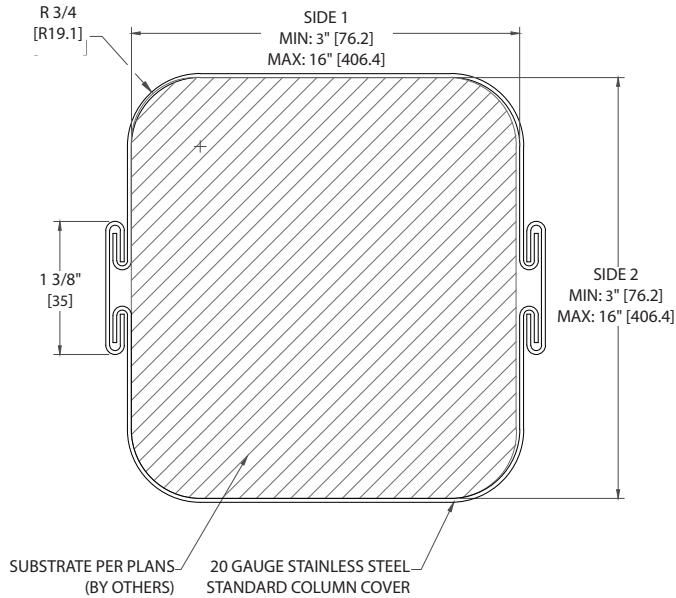

- Offered in custom sizes.
- Offered in 20 gauge sheet
- Height range offered 48" [1219] - 144" [3657]
- Install using supplied adhesive or rivet on (rivets by others)
- Fastener free mounting provides an aesthetic look.
- For use partial height covers only.

IPC.3441/REV.1

Stainless Steel Column Covers

Suggested Specifications

PART 1 – GENERAL

1.01 SUMMARY

- A. Wall panels for wall protection

1.02 SECTION INCLUDES

- A. Stainless Steel Wall Panels

1.03 SUBMITTALS

- A. Product Data: Manufacturer's printed product data for each type of stainless steel wall panel systems specified.
- B. Detail Drawings: Mounting details with the appropriate adhesives for specific project substrates.
- C. Manufacturer's Installation Instruction: Printed installation instructions for stainless steel wall panels.

1.04 DELIVERY, STORAGE AND HANDLING

- A. Deliver materials in unopened factory packaging to the jobsite
- B. Inspect materials at delivery to assure that specified products have been received.
- C. Store in original packaging in a climate controlled location away from direct sunlight.

1.05 PROJECT CONDITIONS

- A. Environmental Requirements: Products must be installed in an interior climate controlled environment.

1.06 WARRANTY

- A. Standard IPC Limited Lifetime Warranty against material and manufacturing defects.

PART 2 - PRODUCTS

2.01 MANUFACTURER

- A. Acceptable Manufacturer:
InPro Corporation,
PO Box 406
Muskego, WI 53150 USA;
Telephone: 800-222-5556, Fax: 888-715-8407,
Internet address: <http://www.inprocorp.com>
- B. Substitutions: Not permitted
- C. Provide all stainless steel wall panels and wall protection from a single source.

2.02 MANUFACTURED UNITS

A. Column Covers

- 1. Stainless Steel Column Cover
 - a. Provide stainless steel column cover systems whose max widths to be 16" [406]
Height - 48" [1219] - 144" [3657]
Panel Thickness - 18 or 20 gauge
Stainless Steel - Type 304 (type 304 conforms to NSF Standard 51)

2.03 MATERIALS

A. Stainless Steel

- 1. Wall Panels
 - a. Thickness - 20 gauge
 - b. Type 304 (conforms to NSF Standard 51)

2.04 COMPONENTS

A. Attachment

1. Covers

- a. Cover shall be adhered with field applied heavy duty adhesive and foam tape.

2.05 FINISH

- A. Stainless Steel: Column cover shall have a No. 4 satin finish.

PART 3 - EXECUTION

3.01 EXAMINATION

- A. Examine areas and conditions in which the wall panel systems will be installed.

- 1. Complete all finishing operations, including painting, before beginning installation of wall panel system materials.
- B. Wall surface shall be dry and free from dirt, grease and loose paint.

3.02 PREPARATION

- A. General: Prior to installation, clean substrate to remove dust, debris and loose particles.

3.03 INSTALLATION

- A. General: Locate the wall panels as indicated on the approved detail drawing for the appropriate substrate and in compliance with the installation instructions. Install wall panels level and plumb at the height indicated on the drawings.

3.04 CLEANING

- A. At completion of the installation, clean surface in accordance with the IPC clean up and maintaina