

HR910 Handrail, Internationally Compliant

Suggested Specifications

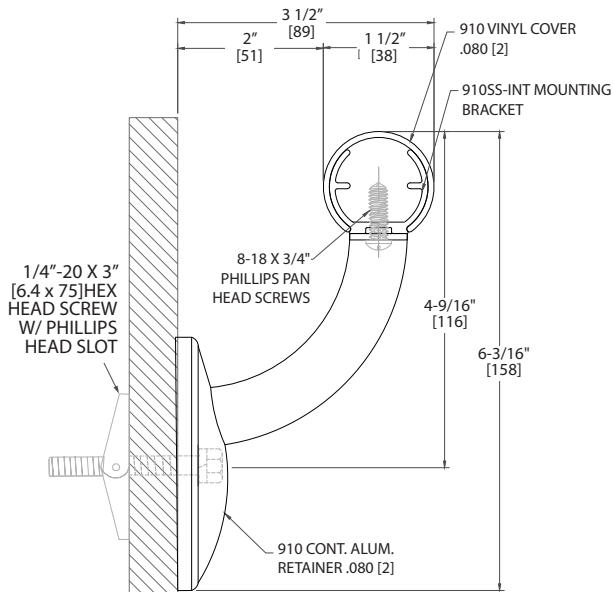

**STAINLESS STEEL MOUNTING
BRACKET (OPTIONAL)
SECTION VIEW**

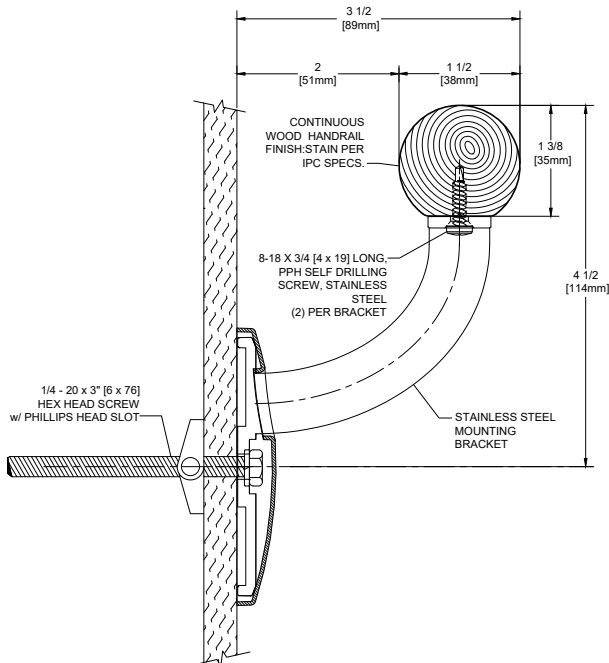

**MOLDED BRACKET
SECTION VIEW**

- 1-1/2" (38mm) round gripping diameter, extends 3-1/2" (89mm) from wall
- Wood returns and corners, standard
- Optional stainless returns
- Design interiors with maple in six stain options.
- Coordinate with Northern Hardwoods® chair rails.
- Meet safety codes with ADA and ANSI compliance

IPC.2229/REV.4

HR910 Handrail, Internationally Compliant

Suggested Specifications

PART 1 - GENERAL

1.01 SUMMARY

A. Handrail system that provides pedestrian safety and wall protection.

1.02 SECTION INCLUDES

A. HR910 Handrail System with a solid round wood or bamboo handrail and stainless steel components that are internationally compliant.

1.03 REFERENCES

A. American National Standards Institute (ANSI)
B. American with Disabilities Act (ADA)
C. Environmental Protection Agency (EPA)
D. Kitchen Cabinets Manufacturers Association (KCMA)
E. National Emission Standards for Hazardous Air Pollutants (NESHAP)

1.04 SYSTEM DESCRIPTION

A. Performance Requirements: Provide wood handrail systems that conform to the following requirements of regulatory agencies and the quality control of Inpro Corporation.

1. Cold, heat and chemical resistance: Provide wood handrail with a finish that complies with the applicable provisions of ANSI/KCMA A161.1-1990 for cold check, heat and chemical resistance.
2. Environmental compliance: Provide wood handrail and with a finish that does not off gas or emit any VOC, after a full cure, as tested in accordance to the EPA, NESHAP, Method 24, 40CFR, Volume 60, Appendix A.
3. Code Compliance: Provide handrails that comply with all current ANSI and ADA requirements.

1.05 SUBMITTALS

A. Product Data: Manufacturer's printed product data for each type of handrail specified.
B. Detail Drawings: Mounting details with the appropriate fasteners for specific project substrates.
C. Samples: Verification samples of handrail, 8" (203mm) long, in full size profiles of each type and color indicated.
D. Manufacturer's Installation Instruction: Printed installation instructions for each handrail.

1.06 DELIVERY, STORAGE AND HANDLING

A. Deliver materials in unopened factory packaging to the jobsite
B. Inspect materials at delivery to assure that specified products have been received.
C. Store in original packaging in a climate controlled location away from direct sunlight.

1.07 PROJECT CONDITIONS

A. Environmental Requirements: Products must be installed in an interior climate controlled environment.

1.08 WARRANTY

A. Standard Inpro Limited Lifetime Warranty against material and manufacturing defects.

PART 2 - PRODUCTS

2.01 MANUFACTURER

A. Acceptable Manufacturer:
Inpro Corporation, PO Box 406
Muskego, WI 53150 USA
Telephone: 800.222.5556
Fax: 888.715.8407
www.inprocorp.com

B. Substitutions: Not permitted
C. Provide all handrails and wall protection from a single source.

2.02 MANUFACTURED UNITS

A. Handrail Profile
1. HR910 Handrail, 1-1/2" (38mm) round gripping diameter, extends 3-1/2" (89mm) from wall.
a. Wood returns and corners, standard.
b. Optional: Stainless Steel Returns
c. Brackets: Stainless Steel or molded thermoplastic

2.03 MATERIALS

A. Wood: Shall be FAS grade, kiln dried, solid maple with moisture content of 5-9%.

2.04 COMPONENTS

A. Returns, outside corners and inside corners shall be solid wood or bamboo and a finish to match handrails.
B. Fasteners: All mounting systems accessories appropriate for substrates indicated on the drawings shall be provided.
C. Stainless Steel: Stainless steel brackets/ returns shall be made of type 201SS with type 304 stainless steel flange cover.
D. Optional molded bracket: Molded bracket and spacer shall be made of injection molded thermoplastic. Bracket shall include a cover to conceal fasteners.

2.05 FINISHES

A. Wood/Bamboo Stain: Color of the handrail to be selected, by the architect, from the Inpro stain selection. Bamboo color shall be natural or carbonized.
B. Wood/Bamboo Finish: Handrail shall be finished with a water-based clear coat finish. Finish shall be a low luster satin finish.
C. Stainless Steel: Stainless steel brackets/ returns shall have a satin finish.
D. Molded bracket: Bracket and spacer shall have a pebbelette texture. Color to be selected by the Architect from the Inpro color palette

PART 3 - EXECUTION

3.01 INSTALLERS

A. Installer should be familiar with the installation of fine finished wood products.

3.02 EXAMINATION

A. Examine areas and conditions in which handrail will be installed.

1. Complete all finishing operations, including painting, before beginning installation of handrail system materials.
2. Wall surface shall be dry and free from dirt, grease and loose paint.

3.03 PREPARATION

A. General: Prior to installation, clean substrate to remove dust, debris and loose particles.

3.04 INSTALLATION

A. General: Locate the handrail as indicated on the approved detail drawing for the appropriate substrate and in compliance with the IPC installation instructions. Install handrail level and plumb at the height indicated on the drawings.

3.05 CLEANING

A. At completion of the installation, clean surfaces in accordance with the IPC clean-up and maintenance instructions.