

Fireline™ Water Guard Series

Fire Barrier Systems - Fire Blanket
Floor to Floor & Roof to Roof

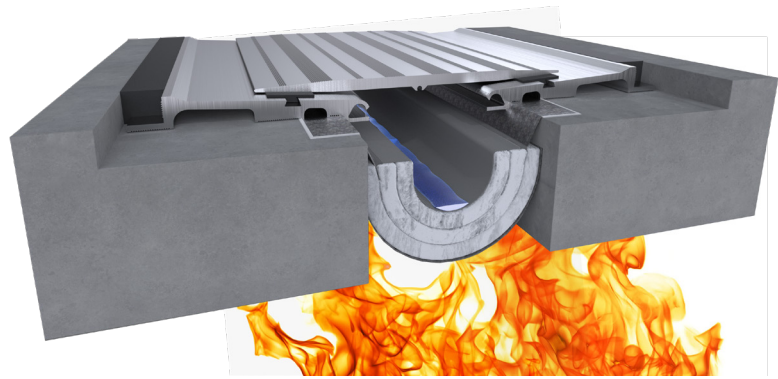

Movement Rating \pm 50%

Product Guide



Thermal



Exterior



Interior



Fire Rated Option



Vapor Barrier Option

- ▶ Integrated water proof silicone cloth protects the blanket system and fire rating during and after construction of open structures such as parking facilities and stadiums. Silicone caulk is required at splices and is supplied by inpro.
- ▶ 1, 2 and 3 hour rated floor systems
- ▶ Tested in accordance with:
 - UL 2079/ ULC S-115 "FTH"
 - (FTH: Rating Fire, Temperature and Hose)
 - ASTM-E119/E1399/E1966
 - BC EN 1366.4
- ▶ 80% movement capability available.
- ▶ \pm 50% (100%) lateral shear capable.
- ▶ Applicable for the following joint widths:
 - 2hr, TM/IM - 4" [102mm] to 24" [610mm]
 - 3hr, TM/IM - 6" [102mm] to 24" [610mm]
 - 2hr/3hr, BM - 6" [102mm] to 24" [610mm]
- ▶ Single sided installation.
- ▶ Pre-attached flanges drastically reduce labor cost and ensure uniform installation.
- ▶ Sections come with factory made male to female splices, eliminating the need for complex field manipulation at seams (see image below).
- ▶ No Fire Caulk required at splices.
- ▶ 4ft long pieces.
- ▶ Flange mounting configurations options meet a variety of project conditions:
 - TM - top (flush) mount
 - IM - inside (recessed) mount
 - BM - bottom Mount
- ▶ Optional drain tubes available.
- ▶ Custom Dual Faced Water Guard available.

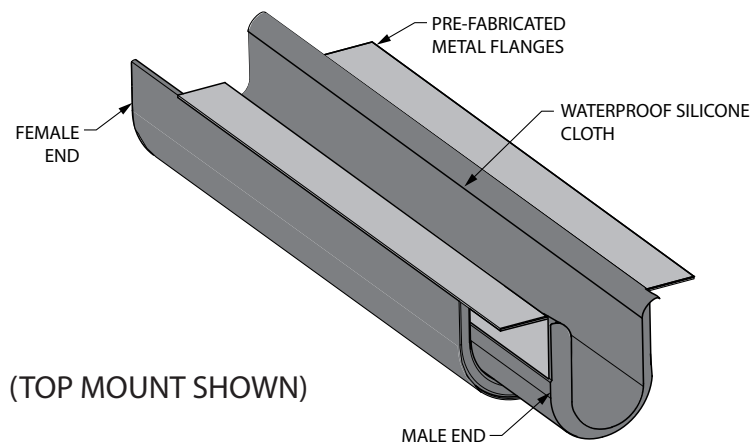

IPC.1977/Rev.7

Fireline™ Water Guard

Fire Barrier Systems

***NOTE:** Rated substrate hourly rating must not exceed the hourly rating of the F520 blanket assembly. Construction of the rated substrate is by others.

Top (Flush) Mount - Floor to Floor
(300-A01-100 System Shown)

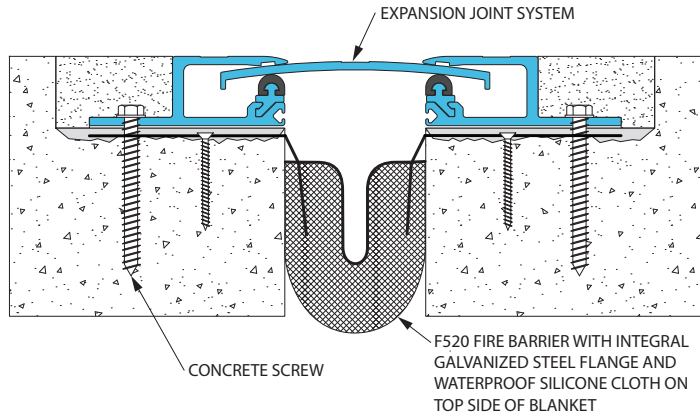

Inside (Recessed) Mount - Floor to Floor
(430-A01-100 System Shown)

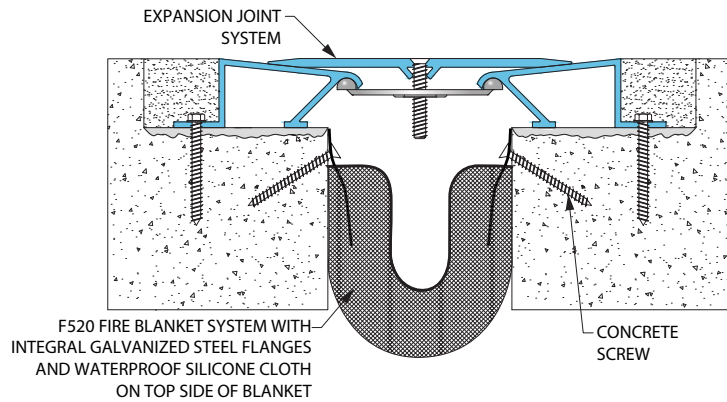

Bottom Mount - Floor to Floor
(300-A01-100 System Shown)

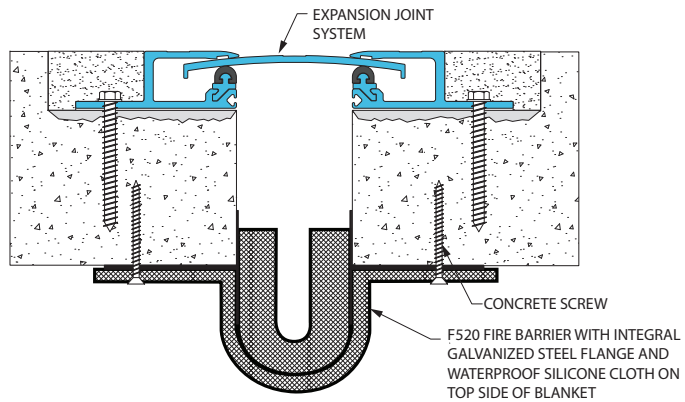

Fireline™ Water Guard

Fire Barrier Systems

Inside Mount (Recessed) System - Roof to Roof
(651-A01 System Shown)

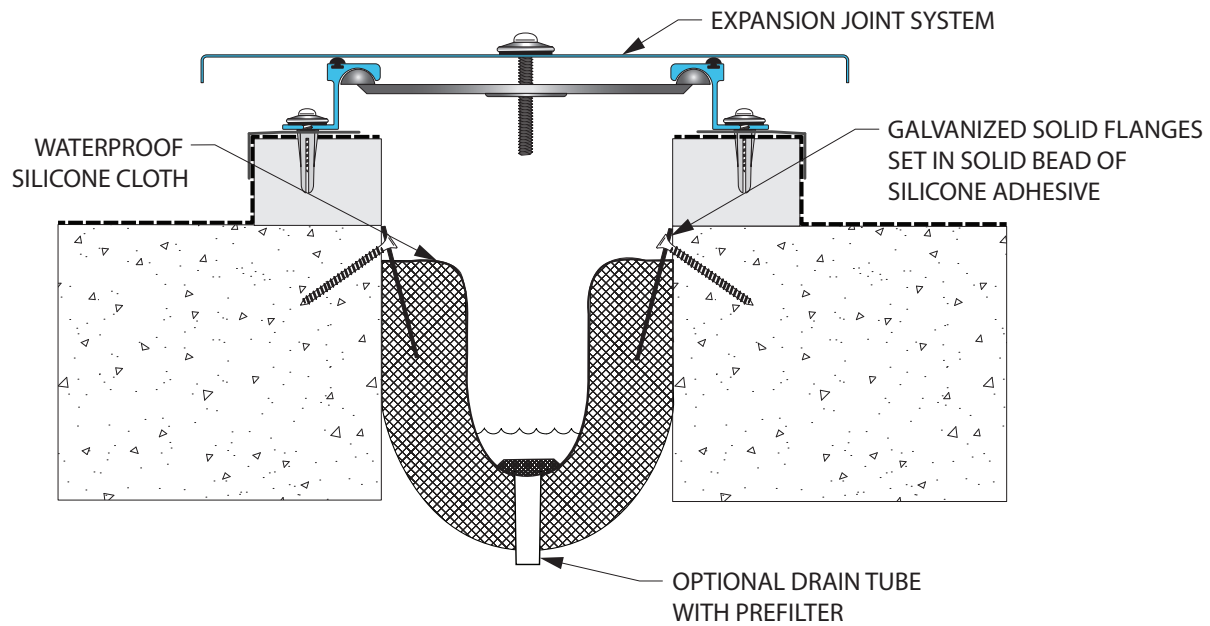

***NOTE:** Rated substrate hourly rating must not exceed the hourly rating of the F520 blanket assembly. Construction of the rated substrate is by others.