

Installation Instructions

940HR Handrail

Please read all instructions before installing handrail.

Important

1. Acclimate materials 24 hrs before installation. Maintain temperature controlled environment after installation
2. Install in accordance with manufacturer's installation instructions. Failure to do so will void the warranty.

Installation tips

1. Cut covers up to 1/16" (1.6mm) longer to ensure a tight fit.
2. Lubricate blades when cutting aluminum to reduce burrs.

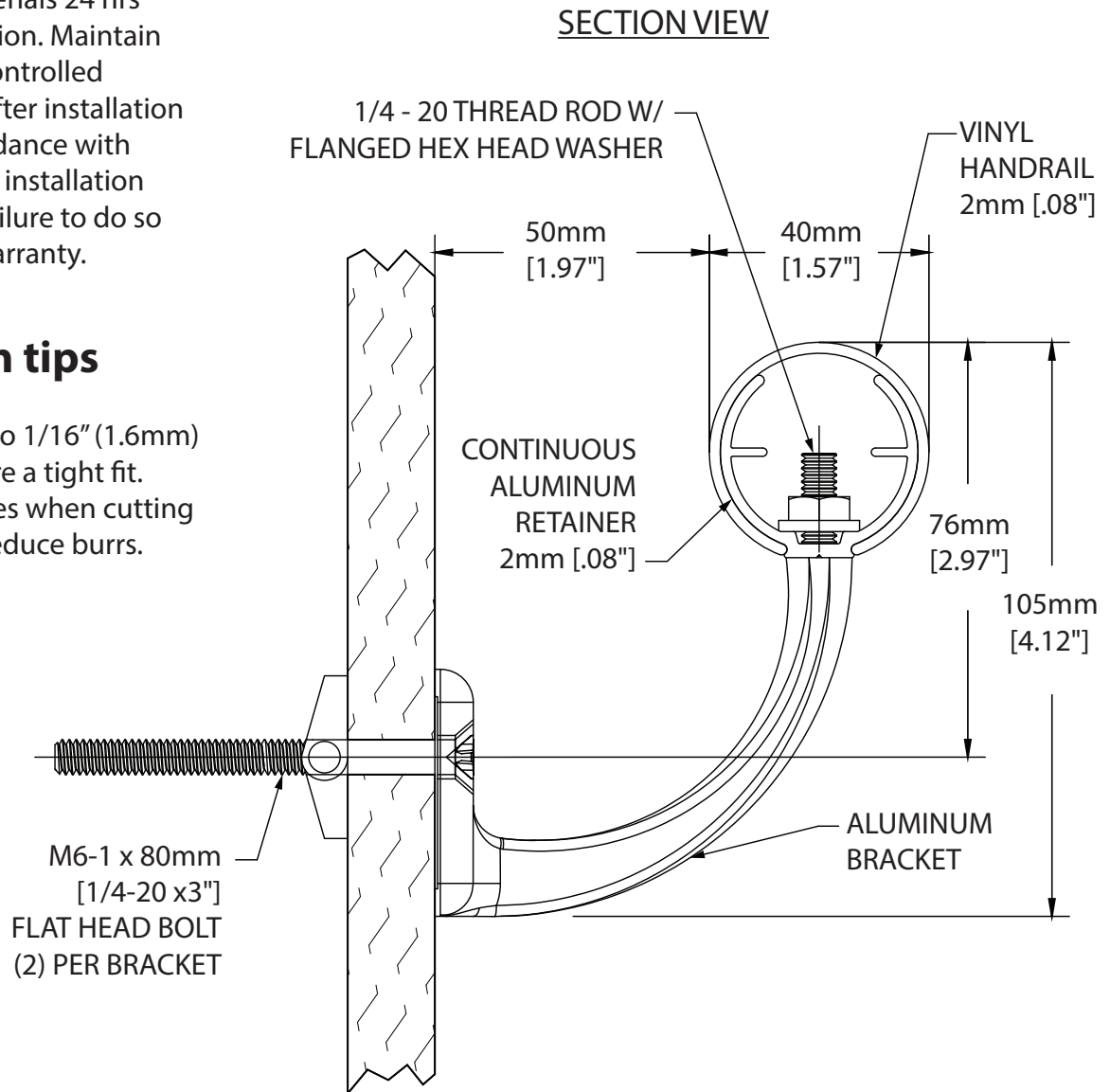

Recommended tools

Safety Glasses, Tape Measure, 3/8" socket for machine screw hex bolt, 7/16" socket for wood screw hex bolt Level, Power Drill, Drill Bits - 1/4" masonry (concrete/concrete block), Power Miter Saw, 10" Blade with 60-80 Carbide Tipped Teeth

IPC.1398/REV.4

IPC® Door + Wall Protection

inpro.com • 800.222.5556 • 262.679.9010

World Headquarters S80 W18766 Apollo Drive, Muskego, WI 53150 USA

Installation Hotline: 866.394.6776

inpro®

Installation Instructions

940HR Handrail

Please read all instructions before installing handrail.

Components and fasteners

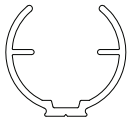

940A
CONTINUOUS
ALUMINUM RETAINER

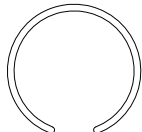

940V
VINYL HANDRAIL
COVER

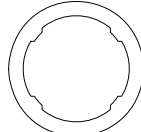

942RVL
REVEAL

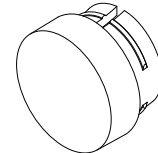

942S
END CAP

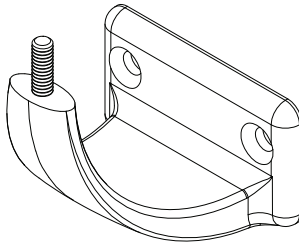

941
ALUMINUM
MOUNTING BRACKET

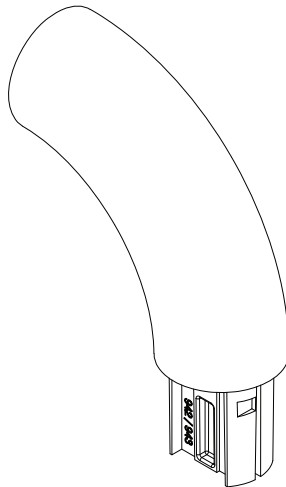

942
RETURN

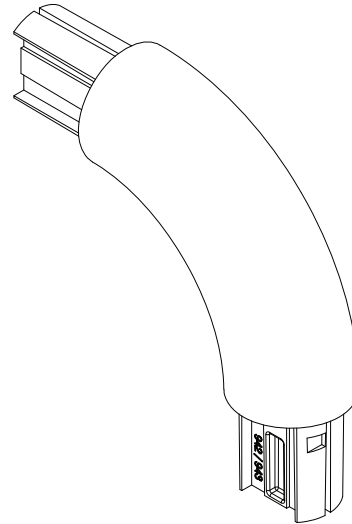

944
INSIDE/OUTSIDE
CORNER

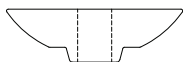

946-P
SPLICE PLATE



1/4"
LOCK WASHER
SPRING REGULAR

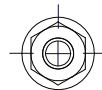

1/4 -20
FLANGED SCREW
HEX NUT

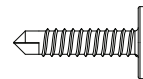

#10-24 x 5/16"
PHILLIPS TRUSS
HEAD SCREW

Wall Condition	Specified Fasteners	Inpro Part #
Drywall Hardware Kit	1/4-20 x 3" Slotted Flat Head Bolt, Toggle Wing Nut and Serated Flange Hex Nut	HWK-941D
Wood Hardware Kit	1/4-20 Toggle Wing Nut and Serated Flange Hex Nut	HWK-941W
942 and 943 Hardware Kit	#8 x 1" Phillips Round Washer Head Self Tap	HW21

IPC® Door + Wall Protection

inpro.com • 800.222.5556 • 262.679.9010

World Headquarters S80 W18766 Apollo Drive, Muskego, WI 53150 USA

Installation Hotline: 866.394.6776

inpro®

Installation Instructions

940HR Handrail

Please read all instructions before installing handrail.

Layout view

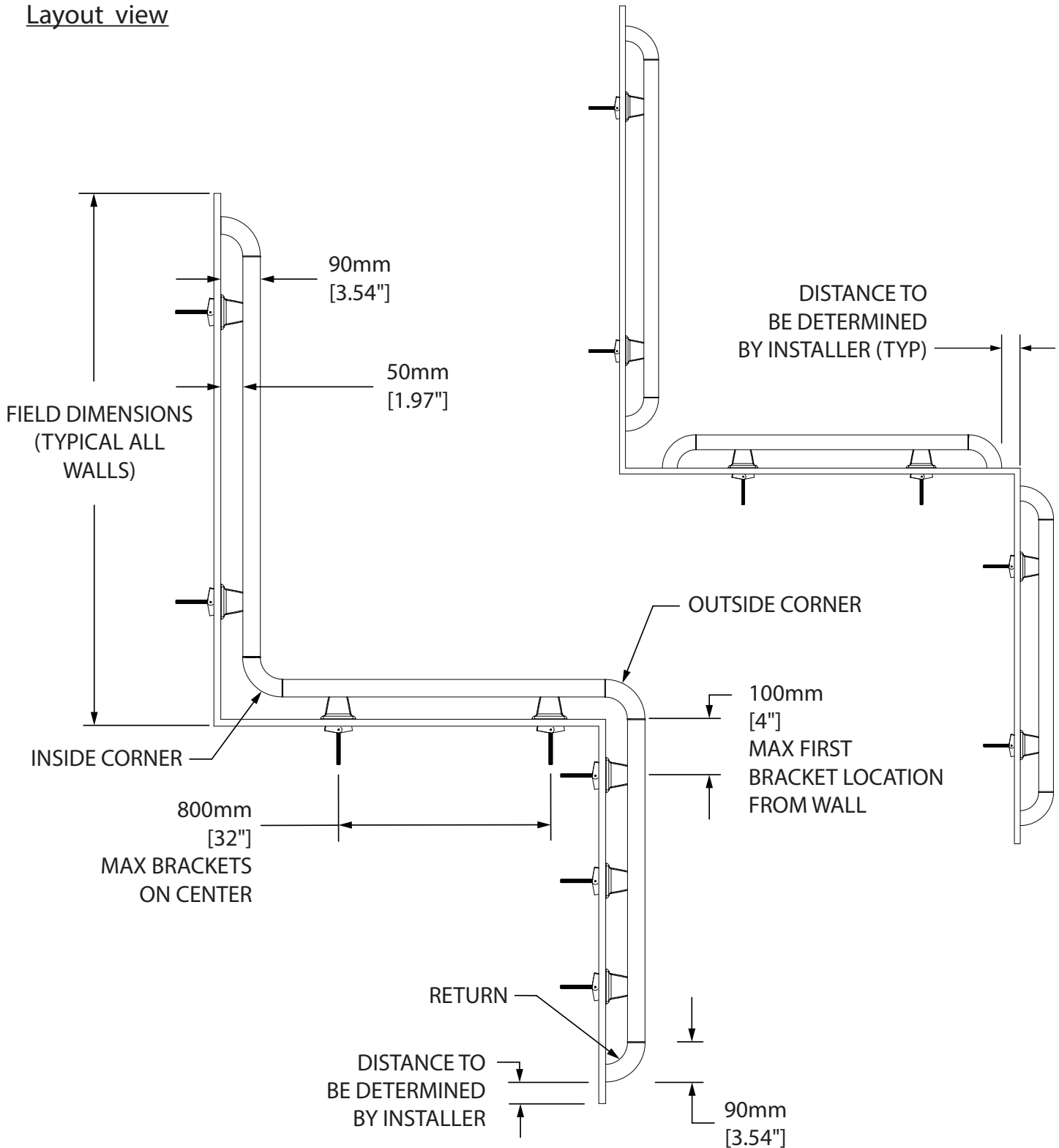

IPC® Door + Wall Protection

inpro.com • 800.222.5556 • 262.679.9010

World Headquarters S80 W18766 Apollo Drive, Muskego, WI 53150 USA

Installation Hotline: 866.394.6776

inpro®

Installation Instructions

940HR Handrail

Please read all instructions before installing handrail.

Exploded view assembly

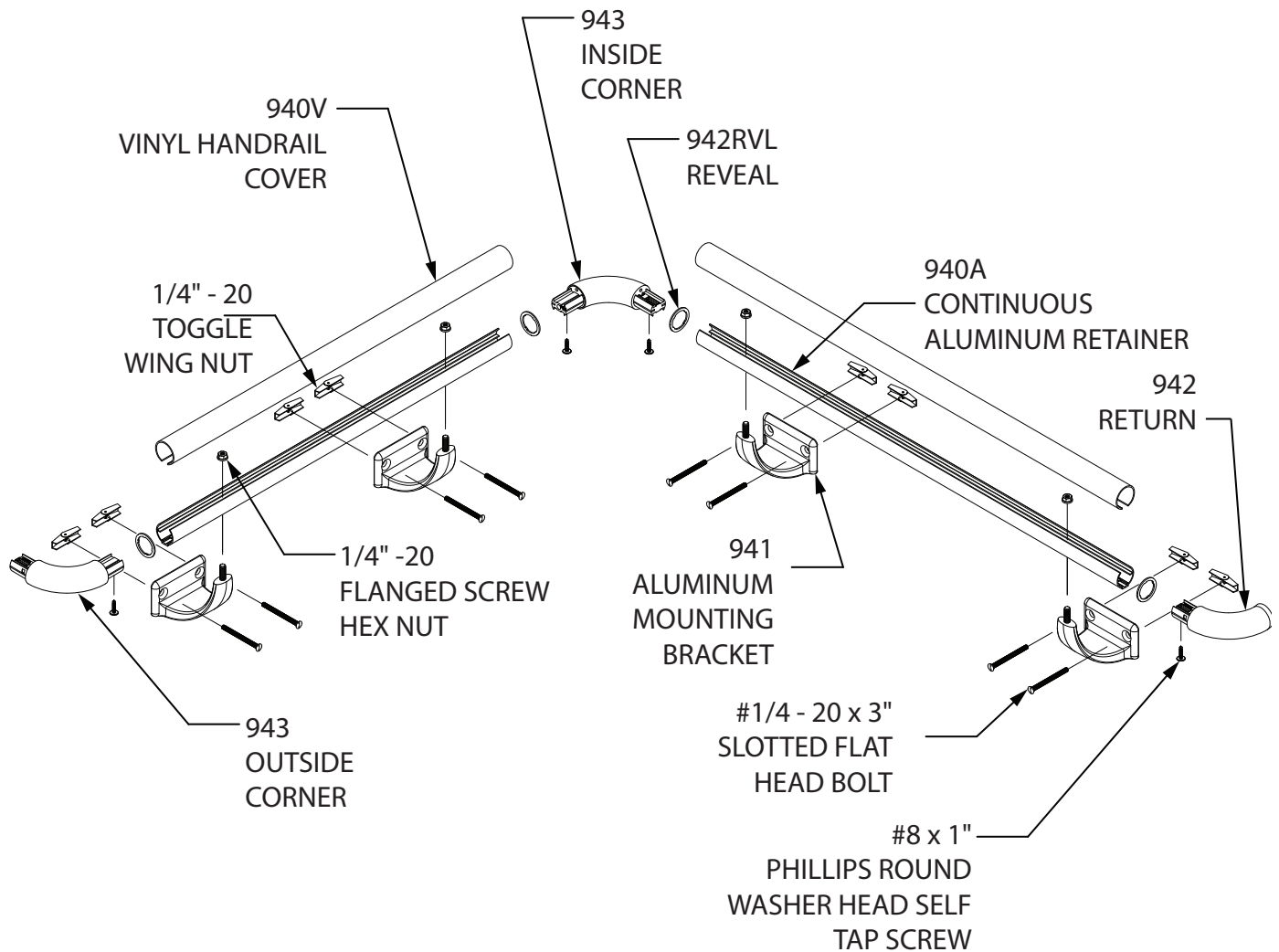

IPC® Door + Wall Protection

inpro.com • 800.222.5556 • 262.679.9010

World Headquarters S80 W18766 Apollo Drive, Muskego, WI 53150 USA

Installation Hotline: 866.394.6776

inpro®

Installation Instructions

940HR Handrail

Please read all instructions before installing. Material must be stored, installed and used in environmentally controlled conditions.

1. Cut aluminum retainer to desired length, leaving allowance for returns, outside corners and inside corners. **See Figure 1.**

FIG. 1

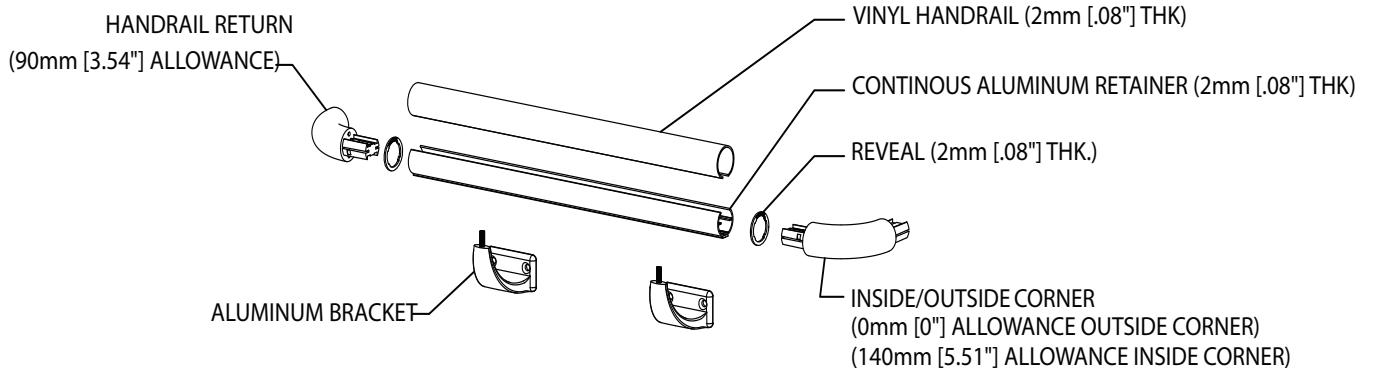
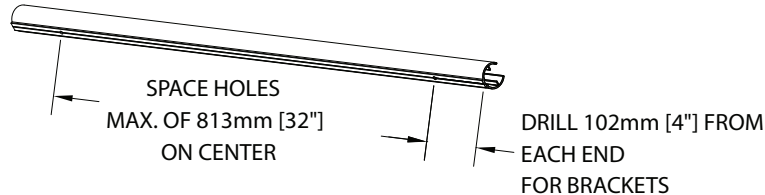
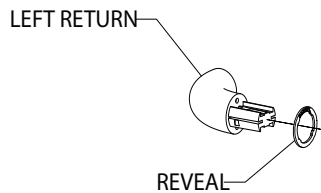

FIG. 2



2. Drill holes in centerline of aluminum retainer for brackets using 7mm [1/4"] drill bit. **See Figure 2.**
3. Slide reveal pieces onto the returns or corners. **See Figure 3.**

FIG. 3



4. Attach returns, inside corners and outside corners to retainer. **See Figure 4.**
5. For lengths longer than 3.66M [12'], use a splice to join sections. Butt the two sections together, using a splice as a template, mark the hole locations. **See Figure 5a.** Drill 7mm [1/4"] holes on the bottom of the aluminum for the splice, and attach with two M5-0.8 x 8mm [#10-24 x 5/16"] Phillips Truss head screws and nuts. (Note: splice must be positioned inside handrail).

See Figure 5b.

FIG. 4

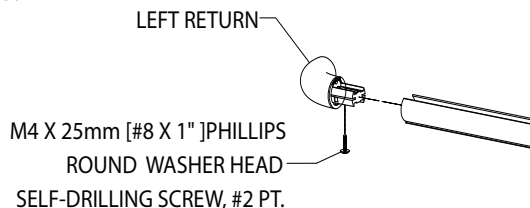

FIG. 5a

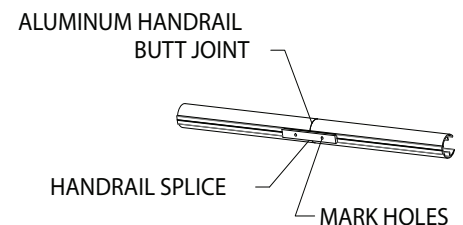
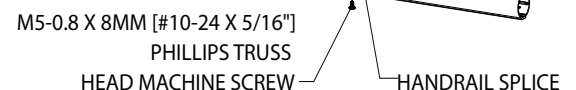

FIG. 5b



Installation Instructions

940HR Handrail

FIG. 6

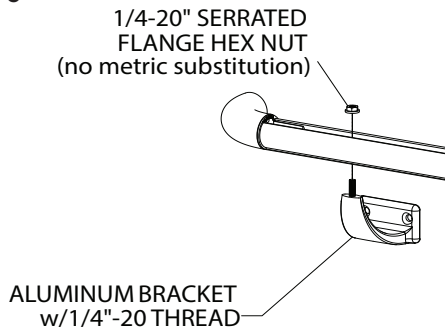

FIG. 7

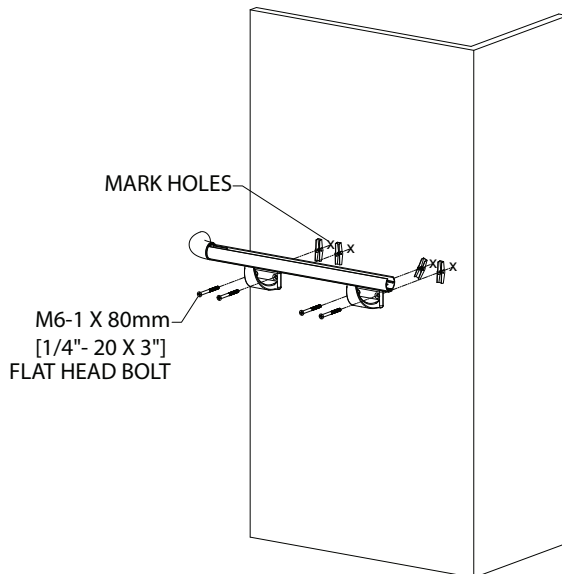
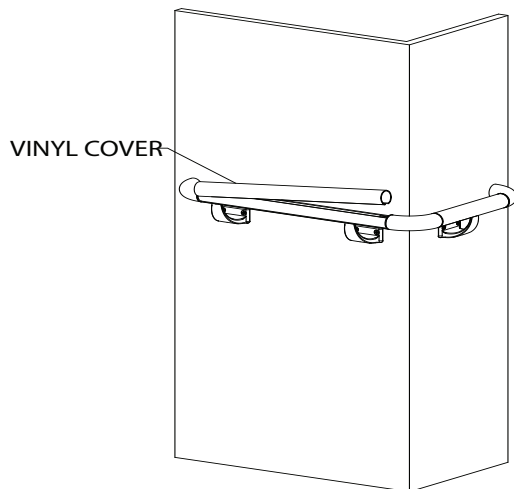

FIG. 8



6. Brackets: Insert post through retainer hole and attach to the retainer with the 1/4-20 nut serrated flange nut.

See Figure 6.

7. Position retainer against wall at desired height. Level and mark bracket holes on wall. Drill marked holes with 20mm [3/4"] drill bit for toggle bolts (drywall installation) or 13mm [1/2"] drill bit for lead anchor (concrete wall installation). Loosely attach mounting bolts to the brackets. Mount on wall, level retainer and tighten screws to secure.

See Figure 7.

8. Cut cover to length between the reveal pieces on the returns and/or corners. (Note: Trim factory edges square before installation). Position cover on retainer at one end and work to the other end by snapping the cover over the retainer. **See Figure 8.**

