

Installation Instructions

910/910FV/G2-910/A910 Handrails

Please read all instructions before installing handrail.

Important

1. Acclimate materials 24 hrs before installation. Maintain temperature controlled environment after installation.
2. Install in accordance with manufacturer's installation instructions. Failure to do so will void the warranty.

Installation tips

1. Cut covers up to 1/16" (1.6mm) longer to ensure a tight fit.
2. Lubricate blades when cutting aluminum to reduce burrs.

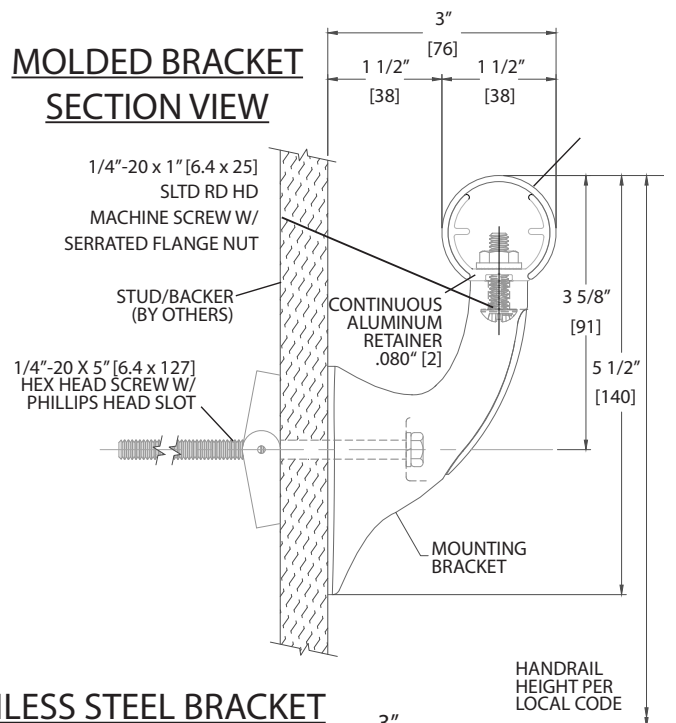

909 STAINLESS STEEL BRACKET SECTION VIEW

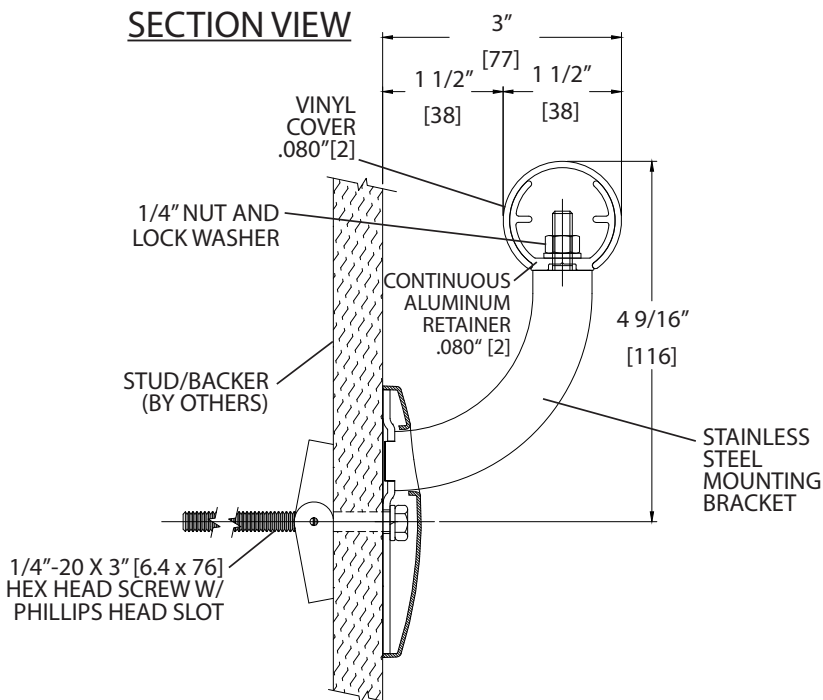

STAINLESS STEEL BRACKET SECTION VIEW

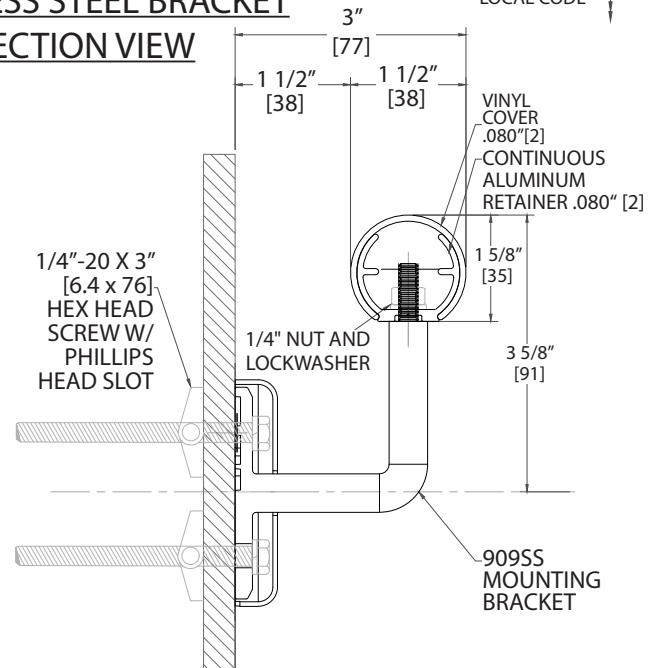

Recommended tools

Safety Glasses, Tape Measure, 3/8" socket for machine screw hex bolt, 7/16" socket for wood screw hex bolt, Level, Phillips and Flat head Screwdrivers, Power Drill, Drill Bits - 1/4" masonry (concrete/concrete block), Power Miter Saw, 10" Blade with 60-80 Carbide Tipped Teeth.

IPC.2128/REV.5

IPC® Door + Wall Protection

inpro.com • 800.222.5556 • 262.679.9010

World Headquarters S80 W18766 Apollo Drive, Muskego, WI 53150 USA

Installation Hotline: 866.394.6776

inpro®

Installation Instructions

910/910FV/G2-910/A910 Handrails

Please read all instructions before installing handrail.

Components and fasteners

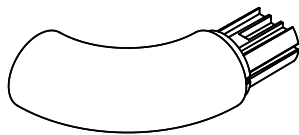

912
LEFT RETURN

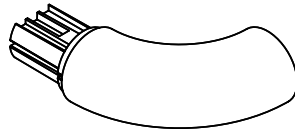

913
RIGHT RETURN

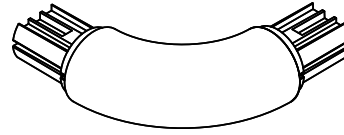

914
INSIDE/OUTSIDE CORNER

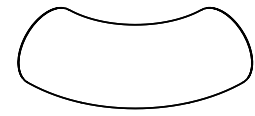

912SS (OPTIONAL)
LEFT/RIGHT RETURN/CORNER
STAINLESS STEEL

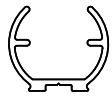

910A
CONTINUOUS
ALUMINUM RETAINER



910V
COVER



910 REVEAL
STANDARD ON
G2-910/910FV

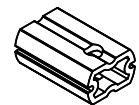

910-SPLINE (OPTIONAL)
FOR STAINLESS STEEL
FITTINGS

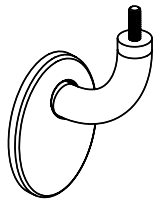

909SS (OPTIONAL)
SS MOUNTING BRACKET

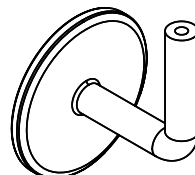

909SS
SS MOUNTING BRACKET

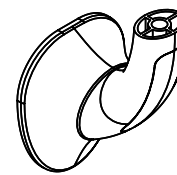

908
MOLDED BRACKET



804-910-SPL

SPLICE



1/4-20

SERRATED
FLANGE NUT



1 1/8" SLOTTED

PAN HEAD
SCREW



1" SLOTTED

ROUND HEAD
SCREW



7/8" SLOTTED

ROUND HEAD
SCREW



#8 X 7/8"

PHILLIPS
PAN HEAD



SET SCREW
(OPTIONAL)

SS RETURN/
CORNER

Wall Conditions	Specified Fasteners	Inpro Part#
Steel Stud/Gypsum Wall	1/4-20 x 3" Phillips hex head Bolt with toggle wing and lock washer	HWK-909D
Concrete/Concrete Block	1/4-20 x 3" Phillips hex head bolt with lead anchor and lock washer	HWK-909C
Wood Stud/Gypsum Wall	1-4" x 3" Hex Head Wood Screw and Lock Washer	HWK-909W
16GA Steel Backer/Gypsum Wall	#4 x 4" Indented hex washer, zinc-plated TEK screw	HW69
Steel Stud or Metal Backer/Drywall (OSHDP)	1/4-20 x 3" Phillips hex head Bolt with Lock Washer and 1/4" Hilti Toggle	HWK-909OD
Concrete/Concrete Block (OSHDP)	1/4" x 3" Torx Hex Washer Head Screw (Hilti Kwik-Con II) and Lock Washer	HWK-909OC
Wood Stud or Wood Backer/Gypsum Wall (OSHDP)	1/4" x 3" Hex Head Wood Screw and Lock Washer	HWK-909OW
Drywall/Gypsum	1/4-20 x 5" Phillips Hex Head with lockwasher, toggle wing nut and 1/4-20 slotted round head bolt with flanged nut	HWK-908D
Concrete/Concrete Block	1/4"-20 x 5" Phillips hex head with lock washer and lead, 1/4-20 x 1" slotted round head bolt with flanged nut	HWK-908C
Wood/Gypsum	1/4" x 5" Hex head wood screw and 1/2"-20 x 1" slotted round head bolt with lockwasher and flanged nut	HWK-908W
OSHDP Drywall	1/4"-20 x 5" Phillips hex head bolt with Hilti Toggle, 1/4-20 x 1" slotted round bolt with lock washer and flanged nut	HWK-908OD
OSHDP Concrete	1/4" x 4" Torx Hex Washer head and 1/4-20 x 1" slotted round head bolt with flanged nut	HWK-908OC
OSHDP Wood	1/4" x 5" Hex head wood screw with 1/4-20 x 1" slotted round head bolt with lockwasher and flanged hex nut	HWK-908OW
Tech Screw	#14 x 4" Tek Screw, 1/4-20 x 1 1/8" slotted bolt, 1/4-20 x 1" slotted round head bolt with lockwasher and flanged nut	HWK-908S

IPC® Door + Wall Protection

inpro.com • 800.222.5556 • 262.679.9010

World Headquarters S80 W18766 Apollo Drive, Muskego, WI 53150 USA

Installation Hotline: 866.394.6776

inpro®

Installation Instructions

910/910FV/G2-910/A910 Handrails

Please read all instructions before installing handrail.

Layout Views

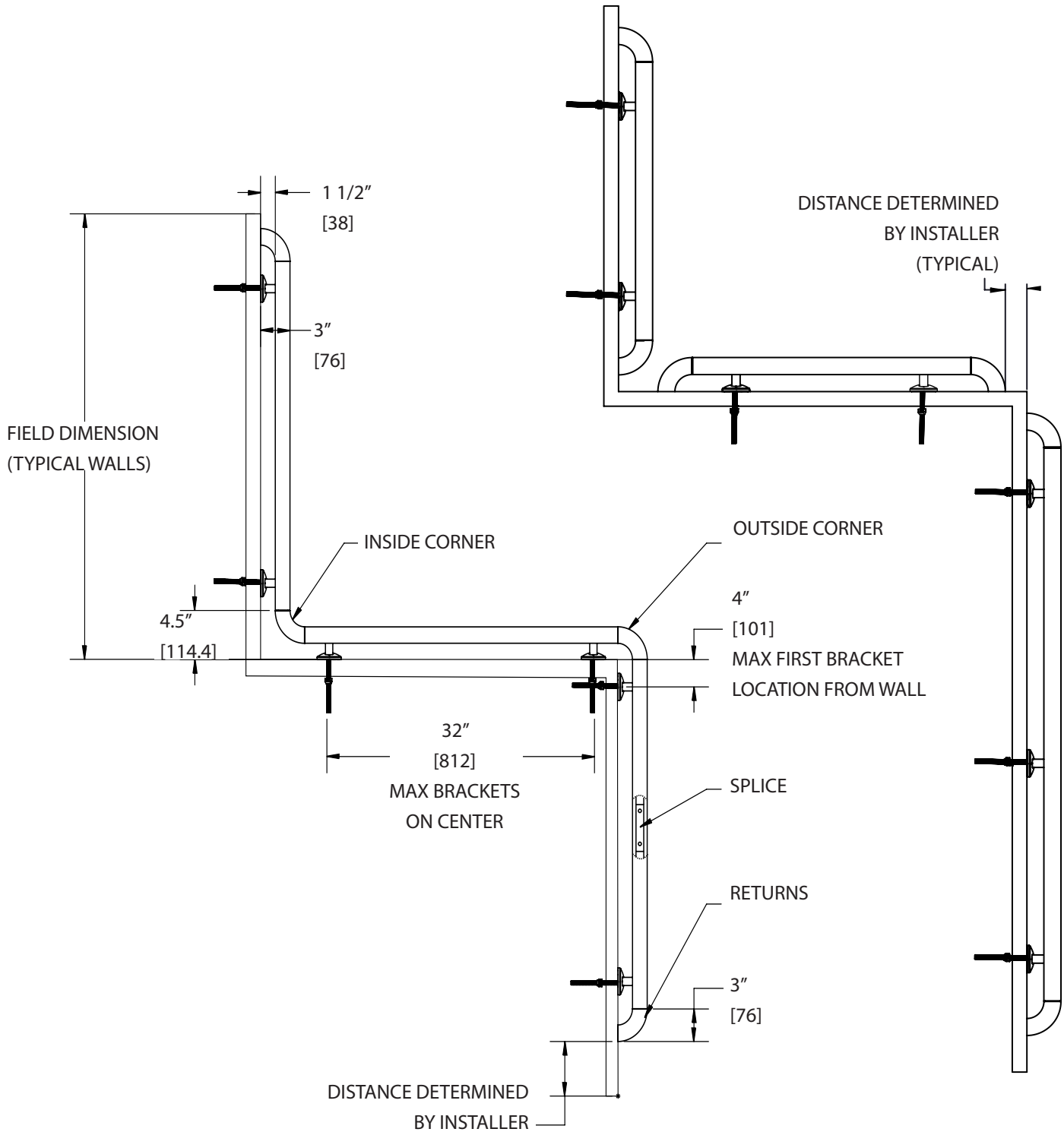

IPC® Door + Wall Protection

inpro.com • 800.222.5556 • 262.679.9010

World Headquarters S80 W18766 Apollo Drive, Muskego, WI 53150 USA

Installation Hotline: 866.394.6776

inpro®

Installation Instructions

910/910FV/G2-910/A910 Handrails

Please read all instructions before installing handrail.

Molded Exploded View Assembly

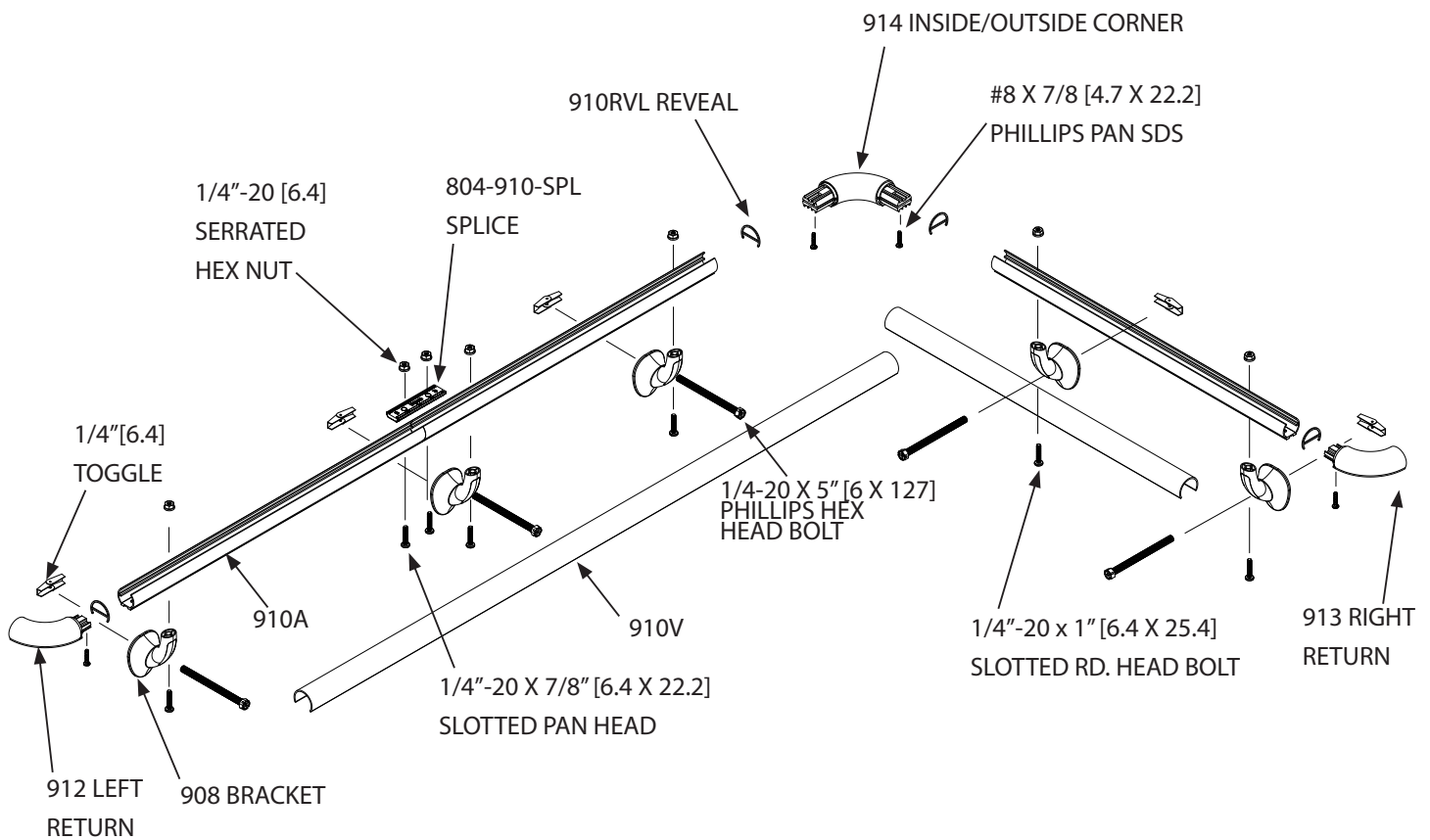

IPC® Door + Wall Protection

inpro.com • 800.222.5556 • 262.679.9010

World Headquarters S80 W18766 Apollo Drive, Muskego, WI 53150 USA

Installation Hotline: 866.394.6776

inpro®

Installation Instructions

910/910FV/G2-910/A910 Handrails

Please read all instructions
before installing handrail.

Stainless Steel Exploded View Assembly

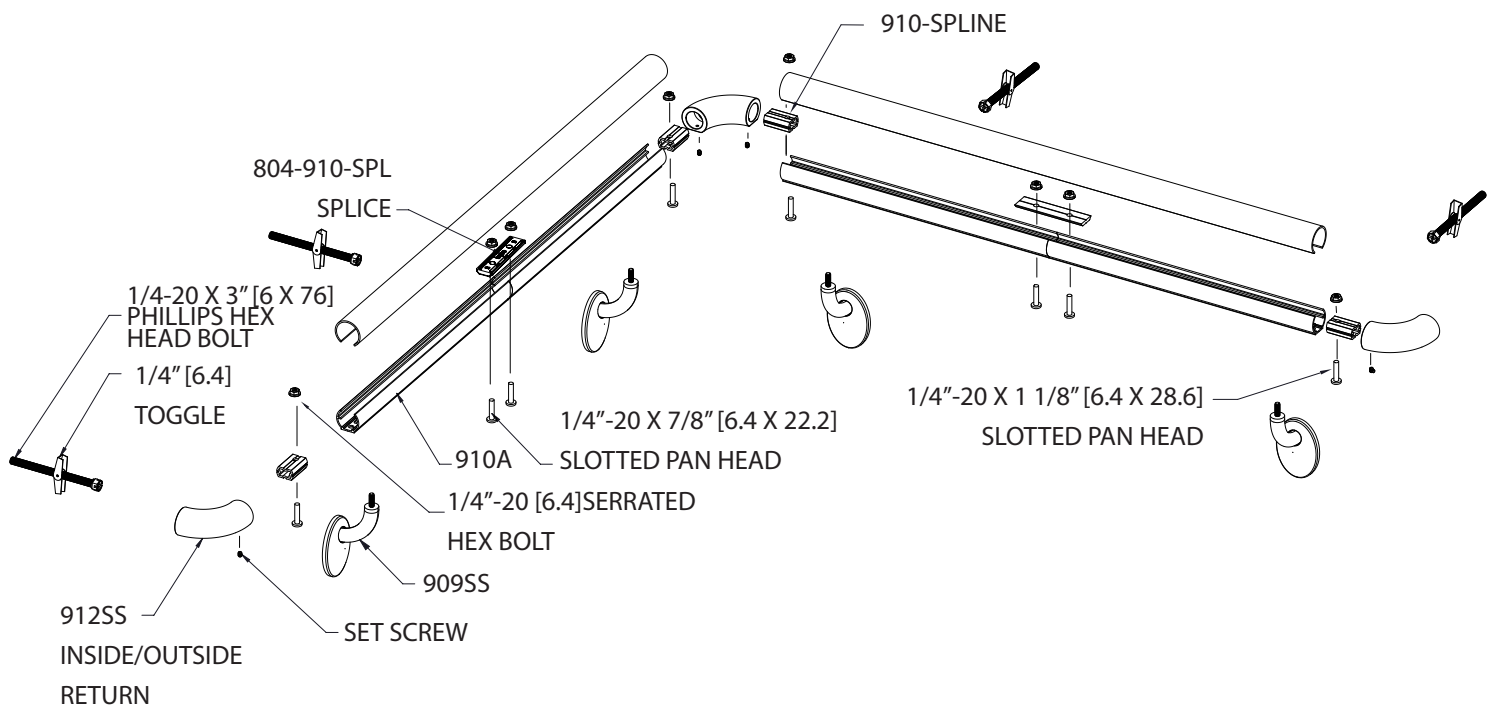

IPC® Door + Wall Protection

inpro.com • 800.222.5556 • 262.679.9010

World Headquarters S80 W18766 Apollo Drive, Muskego, WI 53150 USA

Installation Hotline: 866.394.6776

inpro®

Installation Instructions

910/910FV/G2-910/A910 Handrails

Please read all instructions before installing handrail.

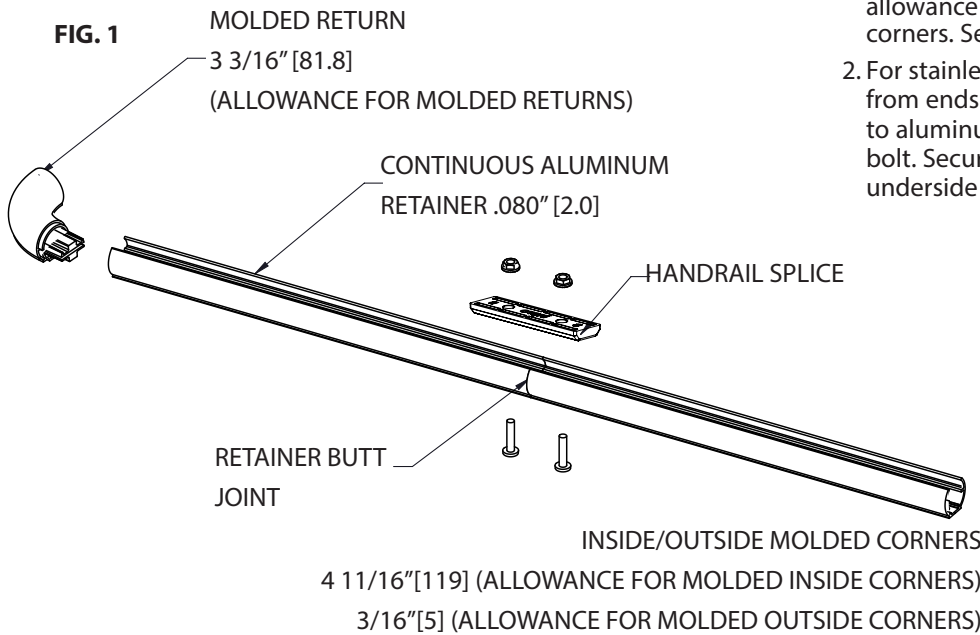

1. Cut aluminum retainer to desired length, leaving allowance for returns, outside corners and inside corners. See Figures 1 and 1a.
2. For stainless steel returns and corners, drill holes 3/8" from ends using a 1/4" [6.4] drill bit. Attach spline to aluminum retainers with 1/4-20 x 1 1/8" [6.4 x 28] bolt. Secure returns/corners to spline-retainer from underside using set screw. See Figure 1a.

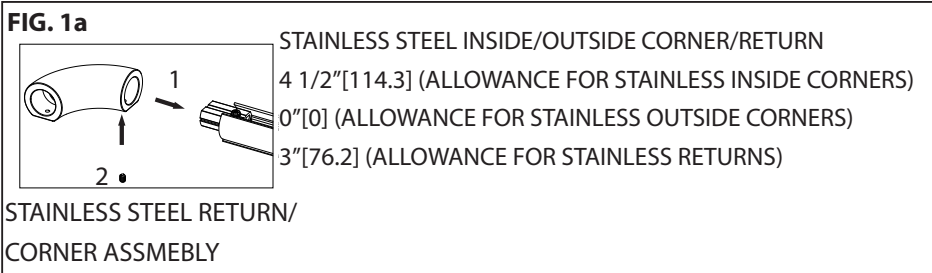

3. Drill holes in centerline of aluminum retainer for brackets and splices using a 1/4" (6mm) drill bit. Attach returns, inside corners and outside corners to retainer. See Figure 2.

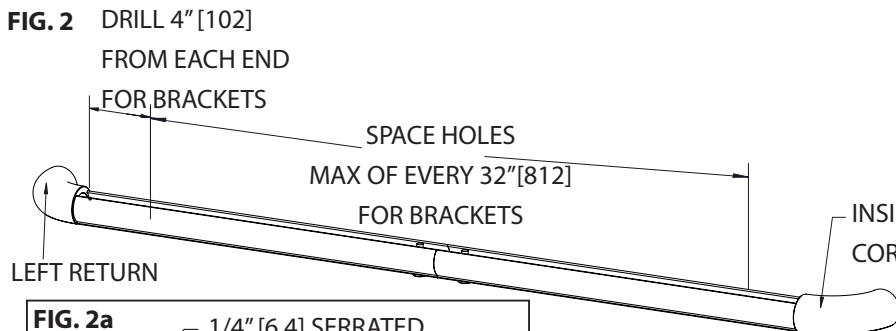

- A. For molded brackets, remove cap and run 1" [25.4] bolt up through small end of bracket and retainer hole to attach. See Figure 2a.
- B. For stainless steel brackets - slip stainless steel cover over post. Insert post through retainer hole and attach. See Figure 2b.

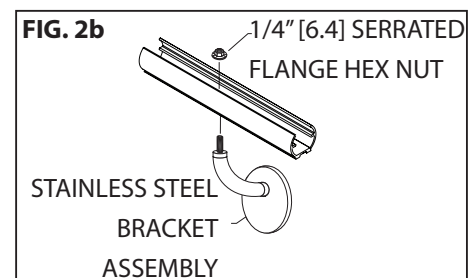
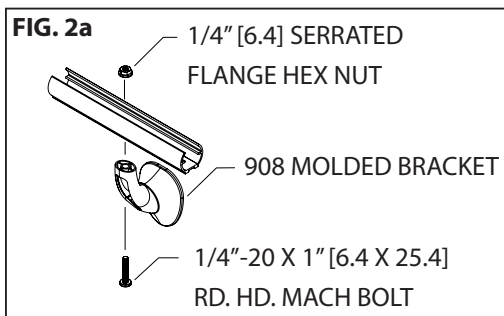

IPC® Door + Wall Protection

inpro.com • 800.222.5556 • 262.679.9010

World Headquarters S80 W18766 Apollo Drive, Muskego, WI 53150 USA

Installation Hotline: 866.394.6776

inpro®

Installation Instructions

910/910FV/G2-910/A910 Handrails

Please read all instructions before installing handrail.

FIG. 3a

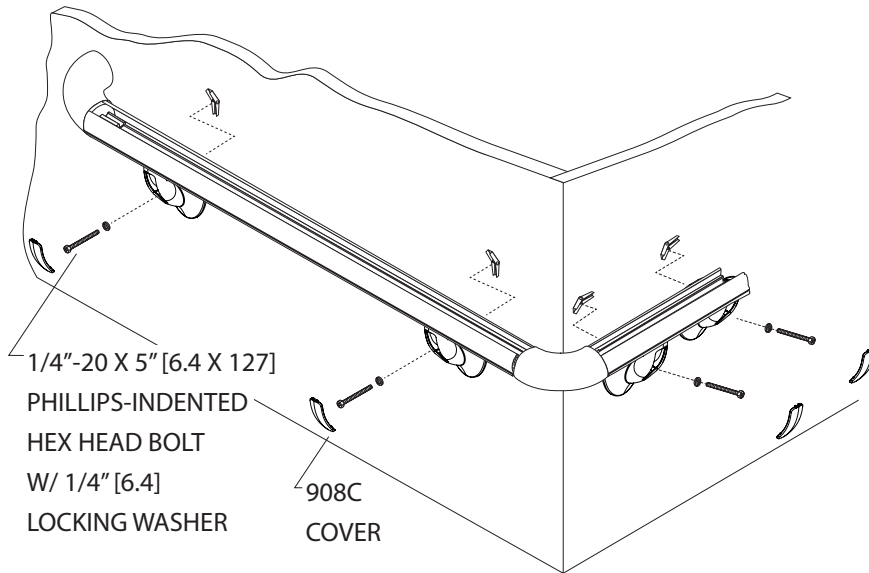

4. Position retainer against wall at desired height. Level and mark bracket holes on wall. Drill marked holes with 3/4" [19mm] drill bit for toggle bolts (drywall installation) or 1/2" [13mm] drill bit for lead anchor (concrete wall installation). Loosely attach mounting bolts to the brackets. Mount on wall, level retainer and tighten screws to secure. See Figure 3a.

NOTE: For stainless steel bracket, snap cover over mounting base when retainer is secure. See Figure 3b.

- 4a. For long runs of handrail, secure each section of aluminum retainer to the next with the supplied splice piece.

NOTE: Make sure you install the splice with side "B" facing up.

FIG. 4

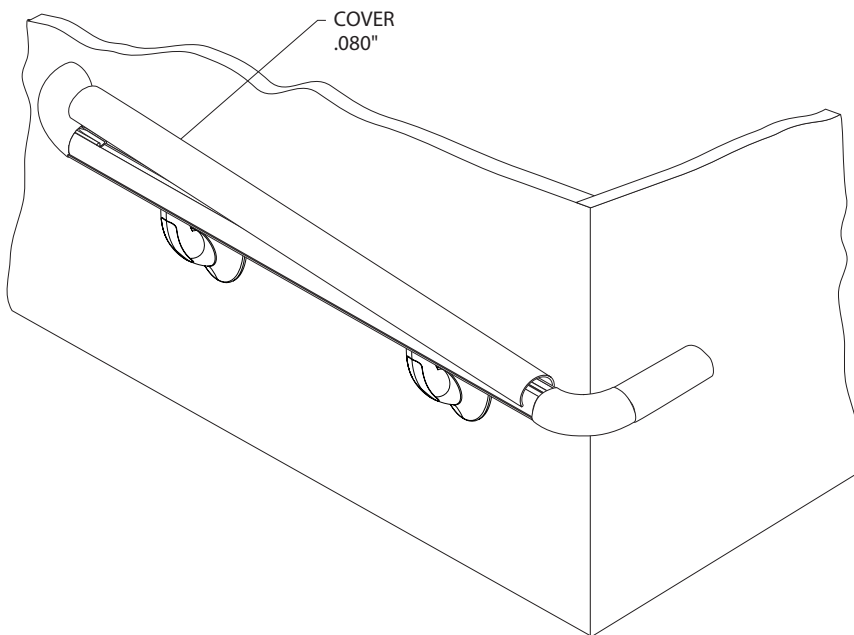
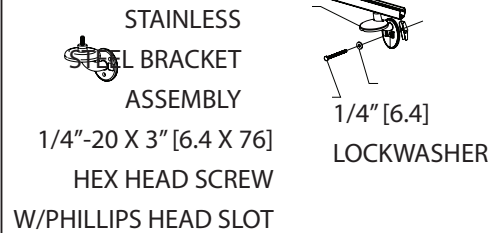

FIG. 3b



5. Cut cover to length between returns and/or corners. (Note: Trim factory edges square before installation). Position cover on retainer at one end and work to the other end by snapping the cover over the retainer. See Figure 4.

IPC® Door + Wall Protection

inpro.com • 800.222.5556 • 262.679.9010

World Headquarters S80 W18766 Apollo Drive, Muskego, WI 53150 USA

Installation Hotline: 866.394.6776

inpro®