

# Installation Instructions

## Joint Systems: 808 - A01/A02

Note: Verify that the structural gap is in conformance with submittal data before beginning installation. If this is a Fire Rated Assembly, install the fire barrier before the Architectural Joint System. Refer to the fire barrier instructions for specific system installation. For installations subject to non-conditioned applications, a thermal gap is required between the end-to-end connections of the frames and covers. When installing in warm conditions (ie- 75F / 22C or greater), the covers can abut each other directly, however during cooler weather installs (70F / 21C or less), the recommended gap width between frames and covers is 1/8" (3mm) min. Prior to installing the next frame in sequence, apply polyurethane sealant (By Others) to the end of the frame / cover before seating the next profile.

Fig. 1

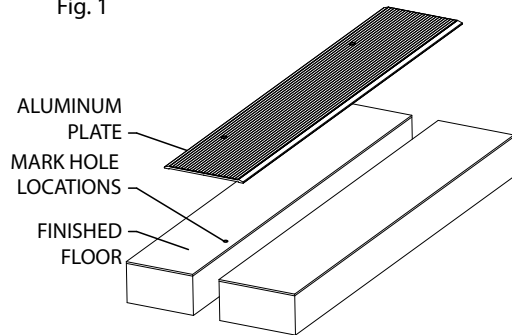

Fig. 2

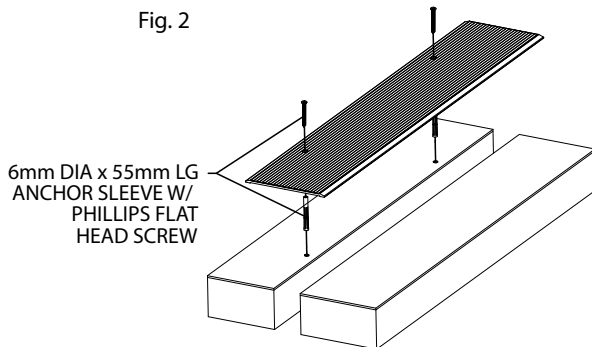

Fig. 3 (COMPLETED INSTALLATION)

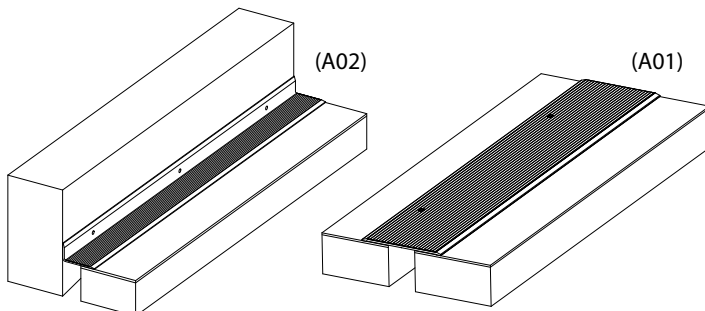

Fig. 1 (808-A01 Floor to Floor)

1. Install the architectural joint system on a level finished floor. This may require adding leveling compound on top of the substrate to provide a smooth mounting surface.

Figure 1

2. Cut the aluminum plates to the desired length.
- 3a. For floor to floor conditions, center plate over the structural gap keeping the predrilled mounting holes on one side.
- b. For floor to wall conditions, press the 2" [51] vertical leg against the wall and make sure the horizontal leg is resting on the floor and that the plate is level.
4. Mark the pre-drilled hole locations on the substrate. Holes should be 6" [152] from each end and spaced 18" [457] OC.
5. Remove the plates.

Figure 2

- 6a. For floor to floor conditions, drill all marked holes on the substrate using a 1/4" [6] drill bit and drill 2" [51] deep.
- b. For floor to wall conditions, drill all marked holes on the substrate using an 1/8" [3] drill bit and drill 2 3/8" [60] deep.
7. Return the plates into position over the drilled hole locations and secure in place.
  - a. Use JK020 - 1/4" x 2-1/4" anchor sleeve with phillips flat head for floor to floor conditions.
  - b. Use JK002 - 3/16" x 2-1/4" flat head Tapcon screws for floor to wall conditions.
8. Clean the exposed surfaces with a non-solvent cleaner, such as 409, as required.

Figure 3 (complete installation)