

# Installation Instructions

Joint System: 674-G02

**Note: Verify that the structural gap is in conformance with submittal data before beginning installation. If this is a Fire Rated Assembly, install the fire barrier before the Architectural Joint System. Refer to the fire barrier instructions for specific system installation. See Reinforced Vapor Barrier Installs (IPC.1698) for proper installation procedures. Available on [inprocorp.com](http://inprocorp.com) under Fire + Moisture Barriers.**

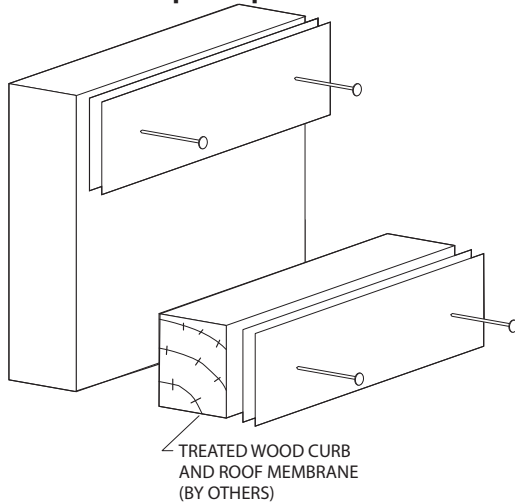

1. Roof membrane or flashing (by others) must be installed on/over supporting curb prior to installation of bellows system. For joint openings over 8" [200] wide, foam bellows must be supported by curb.

a. Optional EPDM Vapor Barrier: Snap a chalk line on the wall per the chart dimensions shown in step 6. Apply substrate compatible adhesive (contractor furnished) 4" below the chalk line on the wall. Trowel membrane compatible mastic to the chalk line on the roof. Starting from one end, embed wall side of the vapor barrier in adhesive to the chalk line. Repeat on the roof side, allowing excess material to drape into the joint opening. If necessary, vapor barrier may be fastened to the substrates with roofing nails. Fold ends up or weep out. (see Figure a)

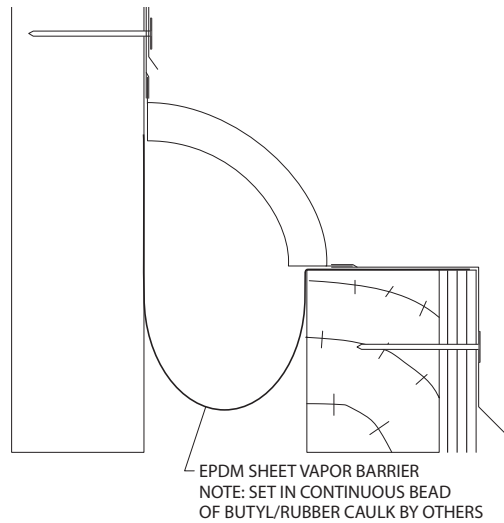
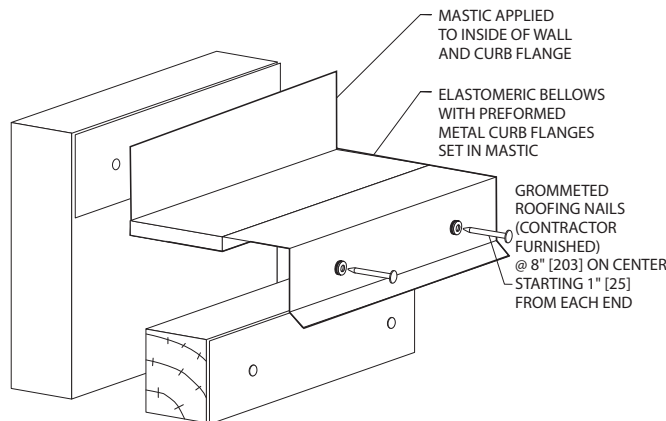

Figure 1

2. Locate and install all intersections (corners, tees, etc.) and transitions first. Trowel compatible mastics (contractor furnished) to the chalk lines at these locations. Embed roof flange in mastic and nail in place using contractor furnished 1 1/4" [31] roofing nails at 2" - 4" [50-100] centers. Embed wall flange in adhesive and fasten in place using contractor furnished fasteners appropriate to wall substrate at 2" - 4" [50-100] centers.
3. To allow for expansion, cut slots in galvanized flanges at 50' [15.24m] intervals. For aluminum, stainless steel and copper flanges, slots should be cut at 25' [7.6m] intervals.

Figure 2

4. Trowel membrane compatible mastic (contractor furnished) onto the under side of each flange. Place bellows at roof edge and set flange onto curb, leaving 1/2" [13] space between intersections/transitions and all succeeding sections. Nail flange using contractor furnished 1 1/4" [32] roofing nails, 4" [100] on center starting 1" [25] from each end.



IPC.1653/REV.1

JOINTMASTER® Expansion Joint Systems

[inpro.com](http://inpro.com) • 800.222.5556 • 262.679.9010

World Headquarters S80 W18766 Apollo Drive, Muskego, WI 53150 USA

Installation Hotline: 866.394.6776

**inpro**®

# Installation Instructions

Joint System: 674-G02

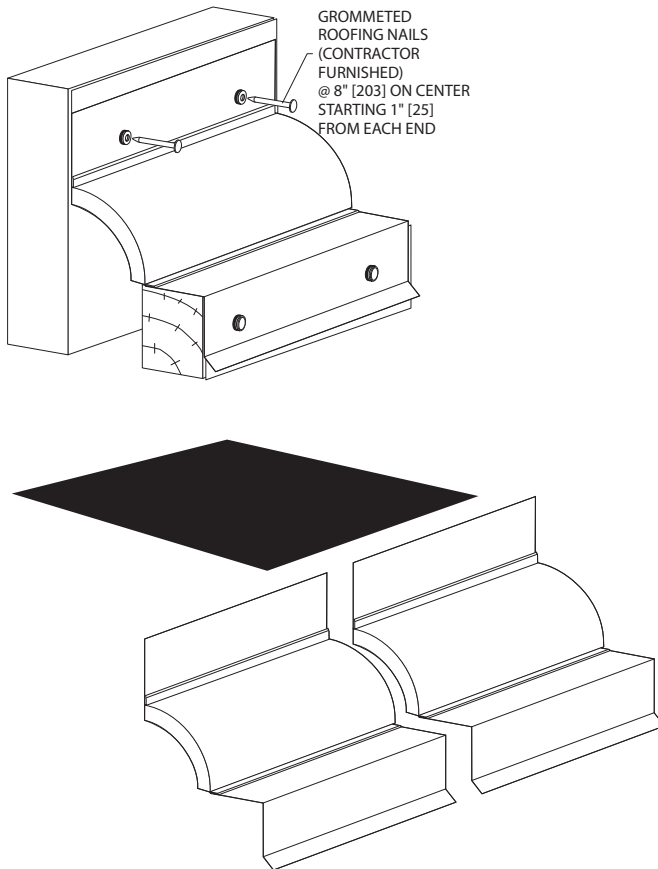

Figure 3

- For the wall flange, snap a chalk line to dimension "A" shown in the chart below. Apply contractor furnished compatible adhesive to the back side of the wall flange. Squeeze bellows and embed wall flange in adhesive to the chalk line. Attach flange using contractor furnished fasteners appropriate to substrate, 8" on center starting 1" from each end.

Joint Opening Width	Dimension "A"
2" (51mm)	6 1/2" (165mm)
3" (76mm)	7 3/4" (197mm)
4" (102mm)	9" (229mm)
5" (127mm)	10 1/4" (260mm)
6" (152mm)	11 1/2" (292mm)
8" (203mm)	14 1/4" (362mm)
10" (254mm)	16 3/4" (425mm)
12" (305mm)	19 1/4" (489mm)

- With all sections in place, follow the splicing instructions to join bellows.
- Counter-flashing and roofing (by others) to be installed over flanges to complete installation.

Figure 4

## Splicing Instructions

- Prime metal flanges and bellows 3" [75] on each side of gap. Allow to dry tack free.
- Apply a 1/4" [6] bead of caulk along the seam where metal flange joins membrane, 3 1/2" [89] long at each side of the gap.
- Remove backing from splice tab, exposing peel and stick adhesive. Install over bellows and flanges, extending tab 4" [100] beyond metal flange.
- Smooth out splice tab into bellows area to prevent "bridging" and to achieve a waterproof seal.
- Adhere splice tab to metal flange and roof system, using membrane compatible adhesive.

