

# 6000

## Bed Locator

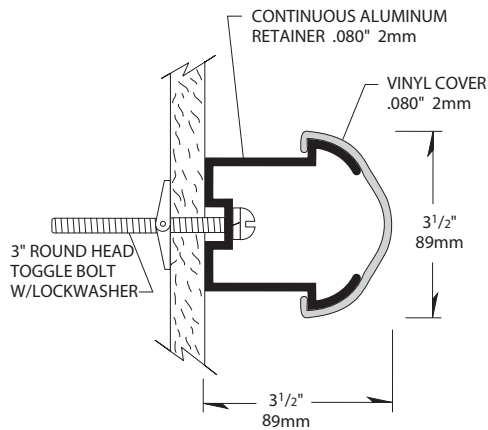

- Extends 3-1/2" (89mm) from wall and provides endcaps that extend 7-3/8" (187mm)
- Mounted on a sturdy .080" (2mm) thick, continuous aluminum retainer
- .080" (2mm) thick, scratch and stain resistant rigid vinyl cover
- Easy installation, clean-up and maintenance
- Meets the most rigorous standards and criteria of chemical emissions as prescribed by the GREENGUARD Environmental Institute
- Has been tested and meets GREENGUARD Environmental Institute's and the state of California's requirements for low emitting products as tested by Air Quality Sciences
- Has been tested and meets the GREENGUARD Children & School chemical emissions levels

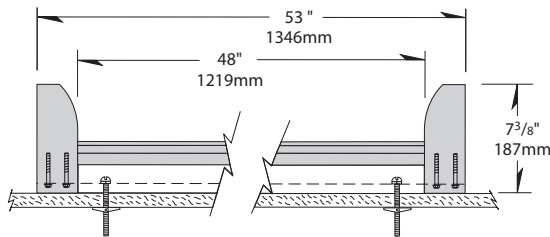

IPC.372/REV.6

# 6000 Bed Locator

## Suggested Specifications

### PART 1 - GENERAL

#### 1.01 SUMMARY

A. Bed Locator system for wall protection and bed alignment

#### 1.02 SECTION INCLUDES

A. 6000 Bed Locator System

#### 1.03 REFERENCES

A. American Society for Testing and Materials (ASTM)

B. National Building Code of Canada (NBC)

C. National Fire Protection Association (NFPA)

D. Society of Automotive Engineers (SAE)

E. Underwriters Laboratory (UL)

F. Underwriters Laboratory of Canada (ULC)

G. Uniform Building Code (UBC)

#### 1.04 SYSTEM DESCRIPTION

A. Performance Requirements: Provide bed locator systems that conform to the following requirements of regulatory agencies and the quality control of IPC Door and Wall Protection Systems™s, InPro Corporation.

1. Fire Performance Characteristics: Provide UL Classified bed locators conforming with NFPA Class A fire rating. Surface burning characteristics, as determined by UL-723 (ASTM E-84), shall be flame spread of 10 and smoke development of 350 - 450. Provide ULC (Canada) listed bed locators conforming to the requirements of the National Building Code of Canada 2010, Subsection 3.1.13. Surface burning characteristics, as determined by CAN/ULC-S102.2, shall be flame spread of 15 and smoke developed of 35.

2. Self Extinguishing: Provide bed locators with a CC1 classification, as tested in accordance with the procedures specified in ASTM D-635-74, Standard Test Method for Rate of Burning and/or Extent and Time of Burning of Self-Supporting Plastics in a Horizontal Position, as referenced in UBC 52-4-1988.

3. Impact Strength: Provide rigid vinyl profile materials that have an Impact Strength of 30.2 ft-lbs/inch of thickness as tested in accordance with the procedures specified in ASTM D-256-90b, Impact Resistance of Plastics.

4. Chemical and Stain Resistance: Provide bed locators that show resistance to stain when tested in accordance with applicable provisions of ASTM D-543.

5. GREENGUARD Certified: Provide GREENGUARD Certified material. Profiles shall meet the requirements of GREENGUARD Certification Standards for Low-Emitting Products and GREENGUARD Product Emission Standard for Children & Schools.

6. Fungal and Bacterial Resistance: Provide rigid vinyl that does not support fungal or bacterial growth as tested in accordance with ASTM G-21 and ASTM G-22.

7. Color Consistency: Provide components matched in accordance with SAE J-1545-(Delta E) with a color difference no greater than 1.0 units using CIE Lab, CIE CMC, CIE LCh, Hunter Lab or similar color space scale systems.

#### 1.05 SUBMITTALS

A. Product Data: Manufacturer's printed product data for

each type of bed locator specified.

B. Detail Drawings: Mounting details with the appropriate fasteners for specific project substrates.

C. Samples: Verification samples of bed locator, 8" (203mm) long, in full size profiles of each type and color indicated.

D. Manufacturer's Installation Instruction: Printed installation instructions for each bed locator.

#### 1.06 DELIVERY, STORAGE AND HANDLING

A. Deliver materials in unopened factory packaging to the jobsite

B. Inspect materials at delivery to assure that specified products have been received.

C. Store in original packaging in a climate controlled location away from direct sunlight.

#### 1.07 PROJECT CONDITIONS

A. Environmental Requirements: Products must be installed in an interior climate controlled environment.

#### 1.08 WARRANTY

A. Standard IPC Limited Lifetime Warranty against material and manufacturing defects.

### PART 2 - PRODUCTS

#### 2.01 MANUFACTURER

A. Acceptable Manufacturer:  
IPC Door and Wall Protection Systems,  
InPro Corporation, PO Box 406 Muskego, WI 53150  
USA; Telephone: 800.222.5556, Fax: 888.715.8407,  
www.inprocorp.com

B. Substitutions: Not permitted

C. Provide all bed locators and wall protection from a single source.

#### 2.02 MANUFACTURED UNITS

A. Bed Locator Profile

1. 6000 Bed Locator, Dimension: 3-1/2" (89mm) height x 3-1/2" (89mm), Standard Length: 53" (1.35m)

#### 2.03 MATERIALS

A. Vinyl: Snap on cover of .080" (2mm) thickness shall be made from chemical and stain-resistant unplasticized polyvinyl chloride (uPVC) with the addition of impact modifiers. No plasticizers shall be added (plasticizers may aid in bacterial growth).

B. Aluminum: Continuous aluminum retainer of .080" (2mm) thickness shall be fabricated from 6063-T5 aluminum, with a mill finish.

#### 2.04 COMPONENTS

A. End caps shall be made of injection molded thermoplastics.

B. Fasteners: All mounting system accessories appropriate for substrates indicated on the drawings shall be provided.

#### 2.05 FINISHES

A. Vinyl Covers: Colors of the bed locator to be selected by the architect from the IPC finish selection. Surface shall have a pebblette texture.

B. Molded Components: End caps shall be of a color matching the bed locator. Surface shall have a pebblette texture.

### PART 3 - EXECUTION

#### 3.01 EXAMINATION

A. Examine areas and conditions in which the bed locator will be installed.

1. Complete all finishing operations, including painting, before beginning installation of bed locator system materials.

B. Wall surface shall be dry and free from dirt, grease and loose paint.

#### 3.02 PREPARATION

A. General: Prior to installation, clean substrate to remove dust, debris and loose particles.

#### 3.03 INSTALLATION

A. General: Locate the bed locator as indicated on the approved detail drawing for the appropriate substrate and in compliance with the IPC installation instructions. Install bed locator level and plumb at the height indicated on the drawings.

B. Installation of 6000 Bed Locator:

1. Attach an end cap on each side of the aluminum retainer. Simply slide the end cap onto the aluminum retainer until the two holes of the end cap line up with the two holes of the aluminum retainer. Fasten the end caps by using two 1/4" screws per end cap.

2. Position aluminum retainer with the end caps attached, against the wall at the desired height. After checking to see that the retainer is level, transfer the locations of the mounting holes to the wall with a marker. Remove aluminum retainer and drill all marked holes on the wall with a 3/4" drill bit.

3. Loosely attach mounting bolts to the aluminum retainer (one 1/4" x 3" round head bolt, one 1/4" lock washer and one toggle wing per hole). Mount the assembled retainer into the holes on the wall. Level the retainer and tighten the bolts to secure the retainer to the wall.

4. Position the vinyl cover on the aluminum retainer starting at the top of the retainer and pivoting the vinyl cover over the bottom of the retainer until it snaps into place.

#### 3.04 CLEANING

A. At completion of the installation, clean surfaces in accordance with the IPC clean-up and maintenance instructions.