

# 50AA/56AA

## Aluminum Wall Guard

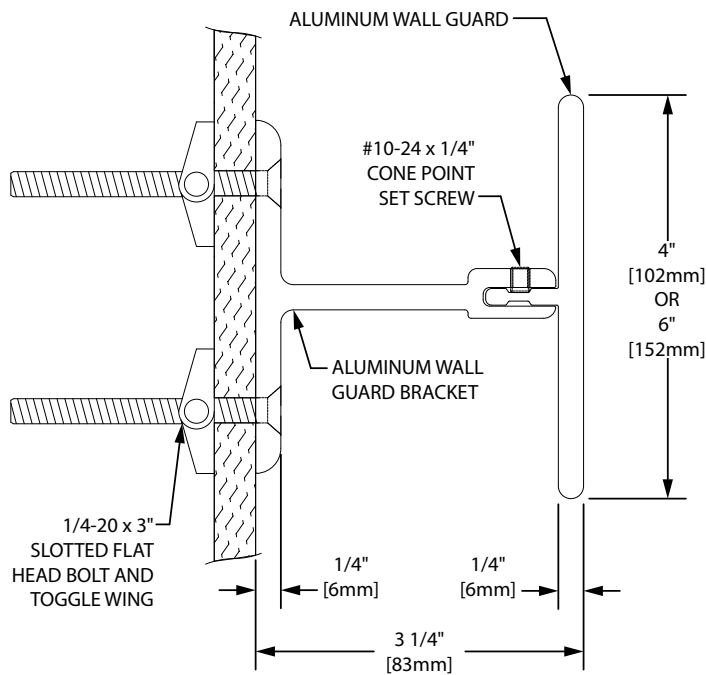

- 50AA, 4" (102mm) of wall protection, extends 3 1/4" (83mm) from wall
- 56AA, 6" (152mm) of wall protection, extends 3 1/4" (83mm) from wall
- Manufactured in 12' (3.66m) lengths. Field cut on site to required lengths.
- 1/4" (6.4mm) thick clear anodized aluminum
- All mounting fasteners are included with each order

IPC.594/REV.6

# 50AA/56AA Aluminum Wall Guard

## Suggested Specifications

---

### **PART 1 - GENERAL**

#### 1.01 SUMMARY

A. Aluminum Wall Guard system for wall protection

#### 1.02 SECTION INCLUDES

A. 50AA/56AA Aluminum Wall Guard Systems

#### 1.03 SUBMITTALS

A. Product data for each type of wall guard specified.

B. Detail drawings indicating mounting details with the appropriate fasteners for specific project substrates.

C. Samples for verification purposes of wall guard, 6" (152mm) long, in full size profiles of each type and color indicated.

D. Cleaning and maintenance instructions for door and wall protection systems.

#### 1.04 DELIVERY, STORAGE AND HANDLING

A. Deliver materials in unopened factory packaging to the jobsite and store in original packaging in a climate controlled location away from direct sunlight.

#### 1.05 PROJECT CONDITIONS

A. Products must be installed in an interior climate controlled environment.

#### 1.06 WARRANTY

A. Standard IPC Limited Lifetime Warranty against material and manufacturing defects.

### **PART 2 - PRODUCTS**

#### 2.01 MANUFACTURER

A. Acceptable Manufacturer:

IPC Door and Wall Protection Systems,  
InPro Corporation, PO Box 406 Muskego, WI 53150  
USA; Telephone: 800.222.5556, Fax: 888.715.8407,  
www.inprocorp.com

B. Substitutions: Not permitted

C. Provide all wall guards and wall protection from a single source.

#### 2.02 MANUFACTURED UNITS

A. Wall Guards

1. Aluminum Wall Guard

Model Size

50AA, 4" (102mm) h x 3 1/4" (83mm) deep,

Manufactured in 12' (3.66m) lengths. Field cut on site to required lengths

56AA, 6" (152mm) h x 3 1/4" (83mm) deep,

Manufactured in 12' (3.66m) lengths. Field cut on site to required lengths

#### 2.03 MATERIALS

A. Aluminum: Wall Guards shall be manufactured from 6063-T5 Aluminum

#### 2.04 FINISHES

A. Aluminum: Provide aluminum wall guard, wall guard brackets and wall guard splice brackets that are clear anodized.

### **PART 3 - EXECUTION**

#### 3.01 EXAMINATION

A. Examine areas and conditions in which the wall guard systems will be installed.

1. Complete all finishing operations, including painting, before beginning installation of wall guards.

B. Wall surface shall be dry and free from dirt, grease and loose paint.

#### 3.02 PREPARATION

A. General: Prior to installation, clean substrate to remove dust, debris and loose particles.

#### 3.03 INSTALLATION

A. General: Locate the wall guard as indicated on the approved detail drawing for the appropriate substrate and in compliance with the IPC installation instructions. Install wall guard level and plumb at the height indicated on the drawings.

B. Installation of Aluminum Wall Guards:

1. Determine the height to the top of the wall guard above the finished floor. Deduct 1/2" (13mm) and snap a chalk line at that height.

2. Use a mounting bracket as a template, position the top edge of the bracket against the chalk line, and mark the location of mounting holes on the wall. Brackets are located 4" (102mm) from the end of the wall guard and spaced a maximum of 32" on center.

3. Drill marked holes with 3/4" drill bit for toggle bolts (drywall installation) or 1/2" drill bit for lead anchor (concrete wall installation). Mount brackets to wall, tighten screws to secure.

4. Position wall guard into mounting brackets. Tighten the wall guard into the brackets with set screws.

Note: When joining two sections of wall guard, use a bracket. The mounting tab of each wall guard section slides halfway into the mounting slot.

5. Position the mounting tabs of the aluminum wall guard in the mounting slot located on the front of each bracket. Tighten the wall guard into the brackets with the socket set screws in each bracket.

#### 3.04 CLEANING

A. At completion of the installation, clean surfaces in accordance with the IPC clean up and maintenance instructions.