

STAINLESS STEEL ARREST CABLE
(8 PER PLATE) (J3Y018 / J3YCRIMP)

SPHERICAL WASHER (7 PER
PLATE @ 18" [457mm] O.C.)
(JK150)

#12 x 2 1/2" [M5x65] HEX HEAD
SHEET METAL SCREW (7 PER
FRAME) (JK221)

#8 x 3/4" [M4 x 19mm] SS SOCKET
HEAD SCREW, SS WASHER AND
#8 [M4] SS LOCK NUT (JK240SS)

#8 x 2 [M4x50] SHEET METAL
SCREW (7 PER FRAME @ 18"
[457mm] O.C.) (JK061)

RUBBER GROMMET (J3Y005)

1/2" [13mm] PAN INFILL
(BY OTHERS)

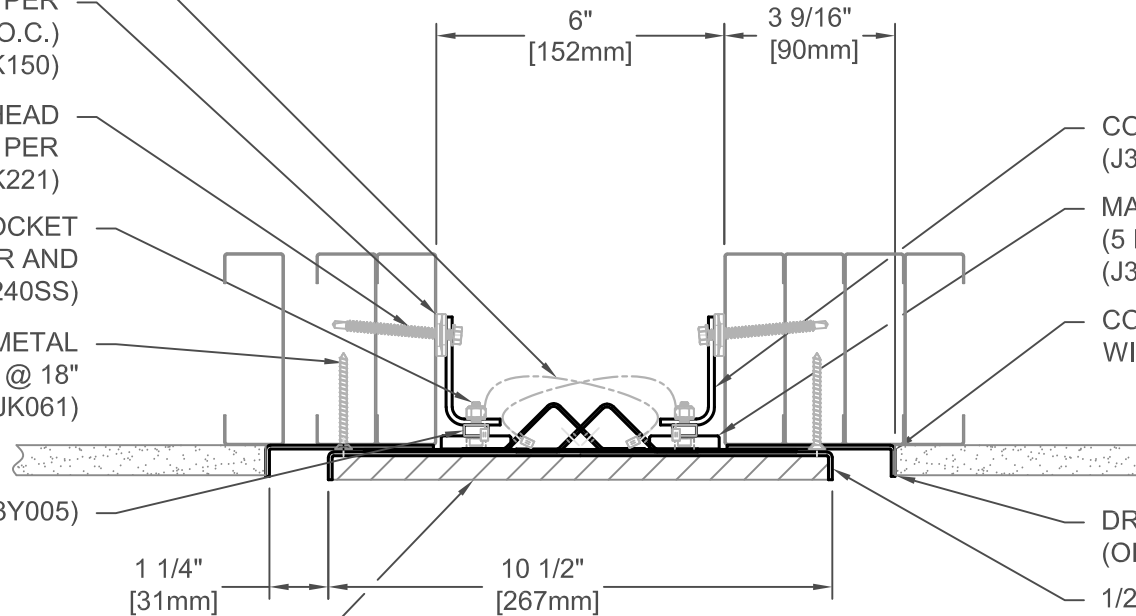

CONT. ALUM. JAMB FRAME
(J3G350-F)

MAGNETIC SECURING SYSTEM
(5 PER SIDE) SPACED EVENLY
(J3M005)

CONT. ALUM. RECESSED
WING (J3A351-F1)

DRYWALL FEATHER COMPOUND
(OPTIONAL, BY OTHERS)

1/2" [13mm] DEEP PAN W/
POP-UP BRACKETS (J3C267-CE)

353-A24-150P

JOINT WIDTH		MOVEMENT			
		MINIMUM		MAXIMUM	
US	mm	US	mm	US	mm
6"	152	2 3/4"	70	12"	305

FINISH: MILL
PROJECT:
CUSTOMER:
LOCATION:

APPLICATION -
CEILING/CEILING CONCEALED PAN EXPANSION JOINT SYSTEM-
ACCEPTS VARIETY OF WALL FINISHES

DATE: 9/4/18

SCALE: 1:4

DOC: CADJM.204/R2

inpro.

For More Information Visit: Inprocorp.com

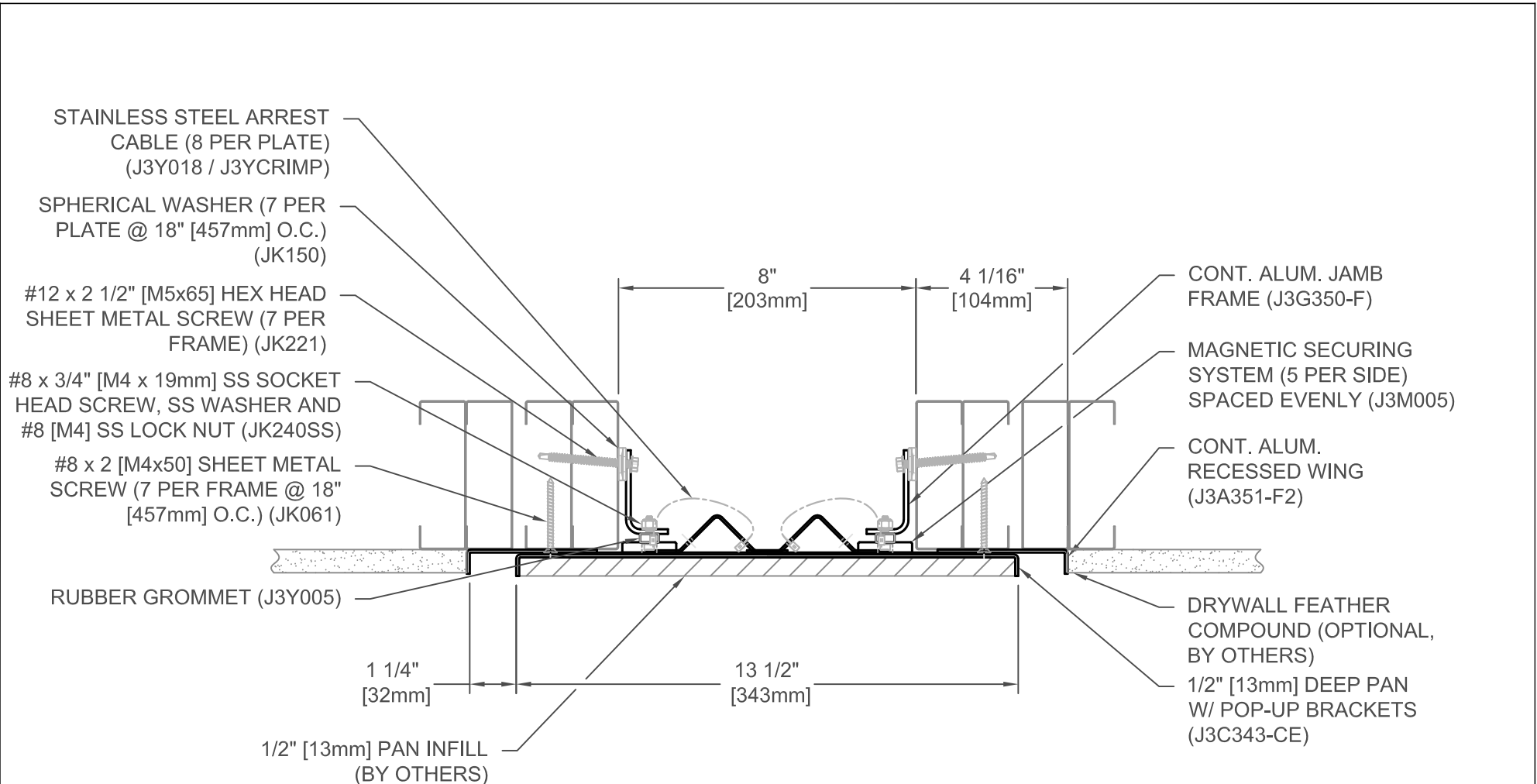

353-A24-200P

JOINT WIDTH		MOVEMENT			
		MINIMUM		MAXIMUM	
US	mm	US	mm	US	mm
8"	203	2 3/4"	70	16"	406

FINISH: MILL
PROJECT:
CUSTOMER:
LOCATION:

APPLICATION -
 CEILING/CEILING CONCEALED PAN EXPANSION JOINT SYSTEM-
 ACCEPTS VARIETY OF WALL FINISHES

DATE:	9/4/18
SCALE:	1:4
DOC:	CADJM.204/R2



For More Information Visit: Inprocorp.com

STAINLESS STEEL ARREST
CABLE (8 PER PLATE)
(J3Y018 / J3YCRIMP)

SPHERICAL WASHER
(7 PER PLATE @ 18"
[457mm] O.C.) (JK150)

#12 x 2 1/2" [M5x65] HEX
HEAD SHEET METAL
SCREW (7 PER FRAME)
(JK221)

#8 x 3/4" [M4 x 19mm] SS
SOCKET HEAD SCREW,
SS WASHER AND #8 [M4]
SS LOCK NUT (JK240SS)

RUBBER GROMMET (J3Y005)

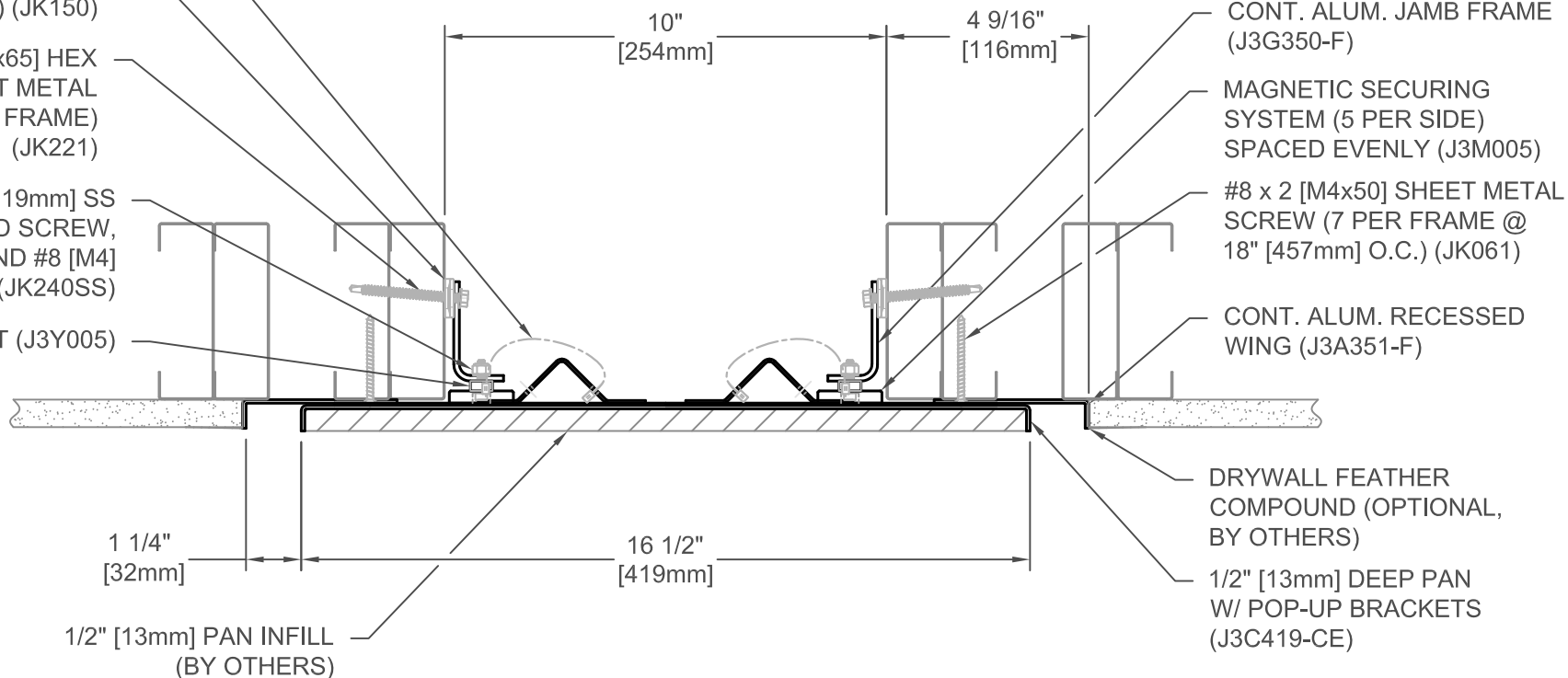

CONT. ALUM. JAMB FRAME
(J3G350-F)

MAGNETIC SECURING
SYSTEM (5 PER SIDE)
SPACED EVENLY (J3M005)

#8 x 2 [M4x50] SHEET METAL
SCREW (7 PER FRAME @
18" [457mm] O.C.) (JK061)

CONT. ALUM. RECESSED
WING (J3A351-F)

DRYWALL FEATHER
COMPOUND (OPTIONAL,
BY OTHERS)

1/2" [13mm] DEEP PAN
W/ POP-UP BRACKETS
(J3C419-CE)

353-A24-250P

JOINT WIDTH		MOVEMENT			
		MINIMUM		MAXIMUM	
US	mm	US	mm	US	mm
10"	254	2 3/4"	70	20"	508

FINISH: MILL
PROJECT:
CUSTOMER:
LOCATION:

APPLICATION -
CEILING/CEILING CONCEALED PAN EXPANSION JOINT SYSTEM-
ACCEPTS VARIETY OF WALL FINISHES

DATE: 9/4/18

SCALE: 1:4

DOC: CADJM.204/R2

inpro.

For More Information Visit: Inprocorp.com

STAINLESS STEEL
ARREST CABLE (8 PER
PLATE) (J3Y018 /
J3YCRIMP)

SPHERICAL WASHER
(7 PER PLATE @ 18"
[457mm] O.C.) (JK150)

#12 x 2 1/2" [M5x65] HEX
HEAD SHEET METAL
SCREW (7 PER FRAME)
(JK221)

#8 x 3/4" [M4 x 19mm] SS
SOCKET HEAD SCREW,
SS WASHER AND #8 [M4]
SS LOCK NUT (JK240SS)

#8 x 2 [M4x50] SHEET
METAL SCREW (7 PER
FRAME @ 18" [457mm]
O.C.) (JK061)

RUBBER GROMMET
(J3Y005)

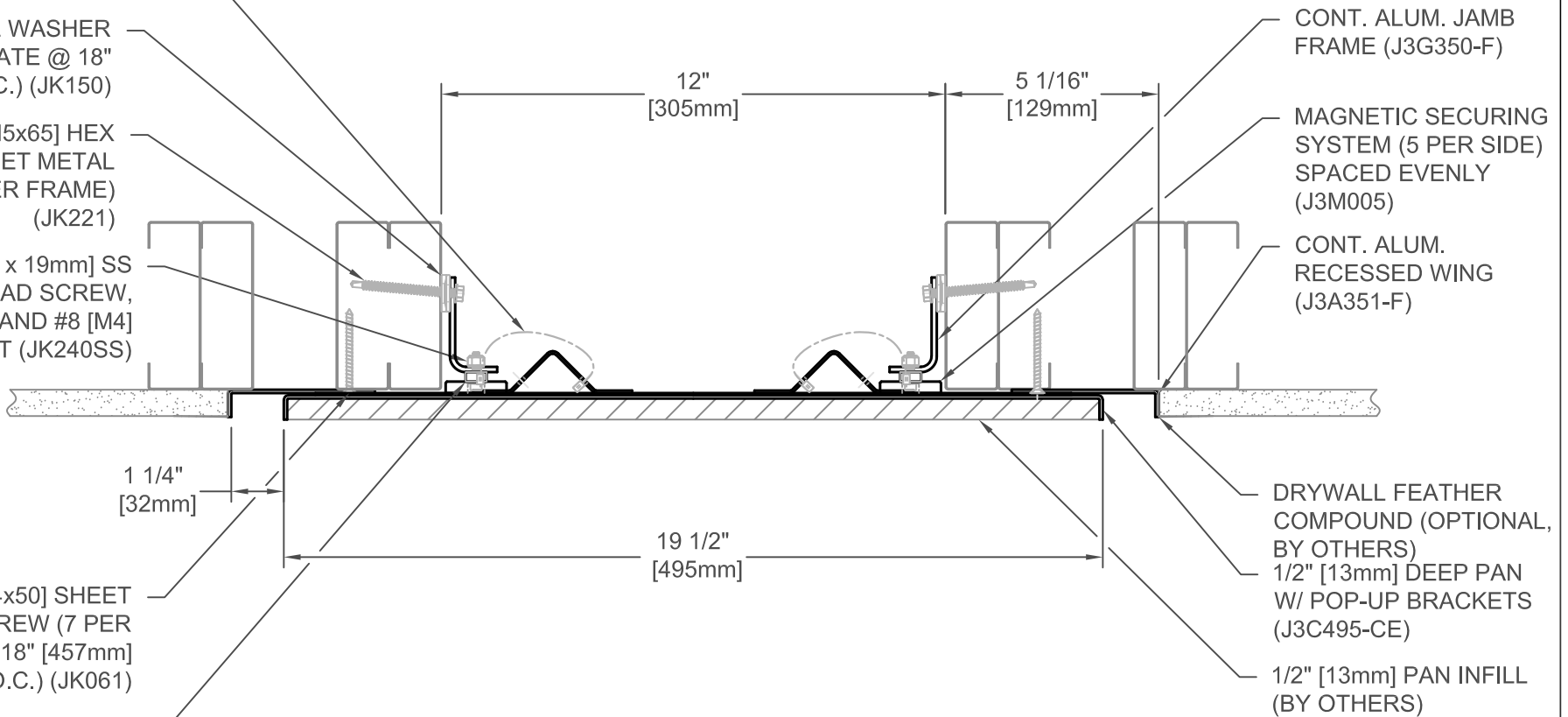

CONT. ALUM. JAMB
FRAME (J3G350-F)

MAGNETIC SECURING
SYSTEM (5 PER SIDE)
SPACED EVENLY
(J3M005)

CONT. ALUM.
RECESSED WING
(J3A351-F)

DRYWALL FEATHER
COMPOUND (OPTIONAL,
BY OTHERS)
1/2" [13mm] DEEP PAN
W/ POP-UP BRACKETS
(J3C495-CE)

1/2" [13mm] PAN INFILL
(BY OTHERS)

353-A24-300P

JOINT WIDTH		MOVEMENT			
		MINIMUM		MAXIMUM	
US	mm	US	mm	US	mm
12"	305	2 3/4"	70	24"	610

FINISH: MILL
PROJECT:
CUSTOMER:
LOCATION:

APPLICATION -
CEILING/CEILING CONCEALED PAN EXPANSION JOINT SYSTEM-
ACCEPTS VARIETY OF WALL FINISHES

DATE:	9/4/18
SCALE:	1:4
DOC:	CADJM.204/R2

inpro.

For More Information Visit: Inprocorp.com

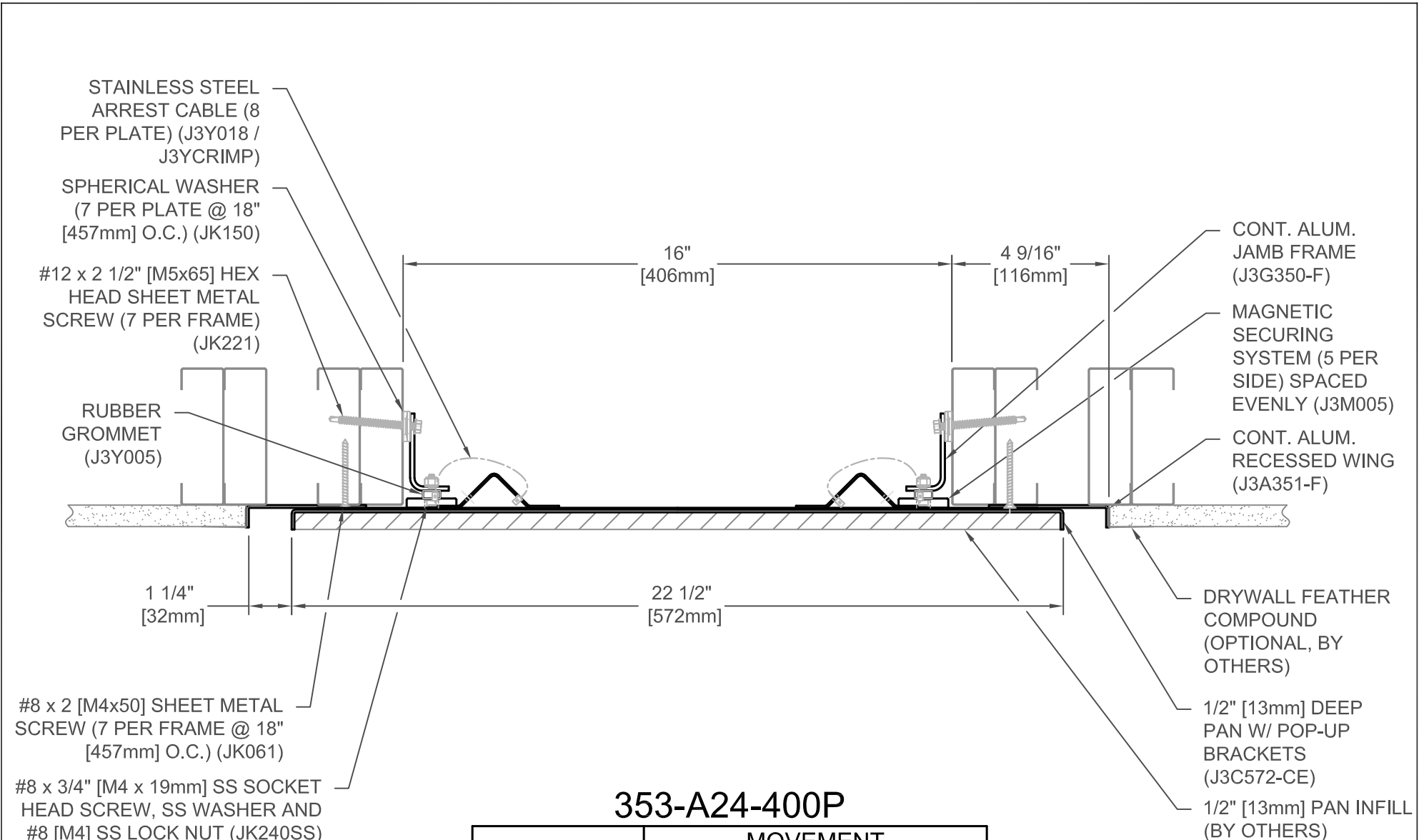

353-A24-400P

JOINT WIDTH		MOVEMENT			
		MINIMUM		MAXIMUM	
US	mm	US	mm	US	mm
16"	406	2 3/4"	70	32"	813

FINISH: MILL
PROJECT:
CUSTOMER:
LOCATION:

APPLICATION -
 CEILING/CEILING CONCEALED PAN EXPANSION JOINT SYSTEM-
 ACCEPTS VARIETY OF WALL FINISHES

DATE:	9/4/18
SCALE:	1:4
DOC:	CADJM.204/R2



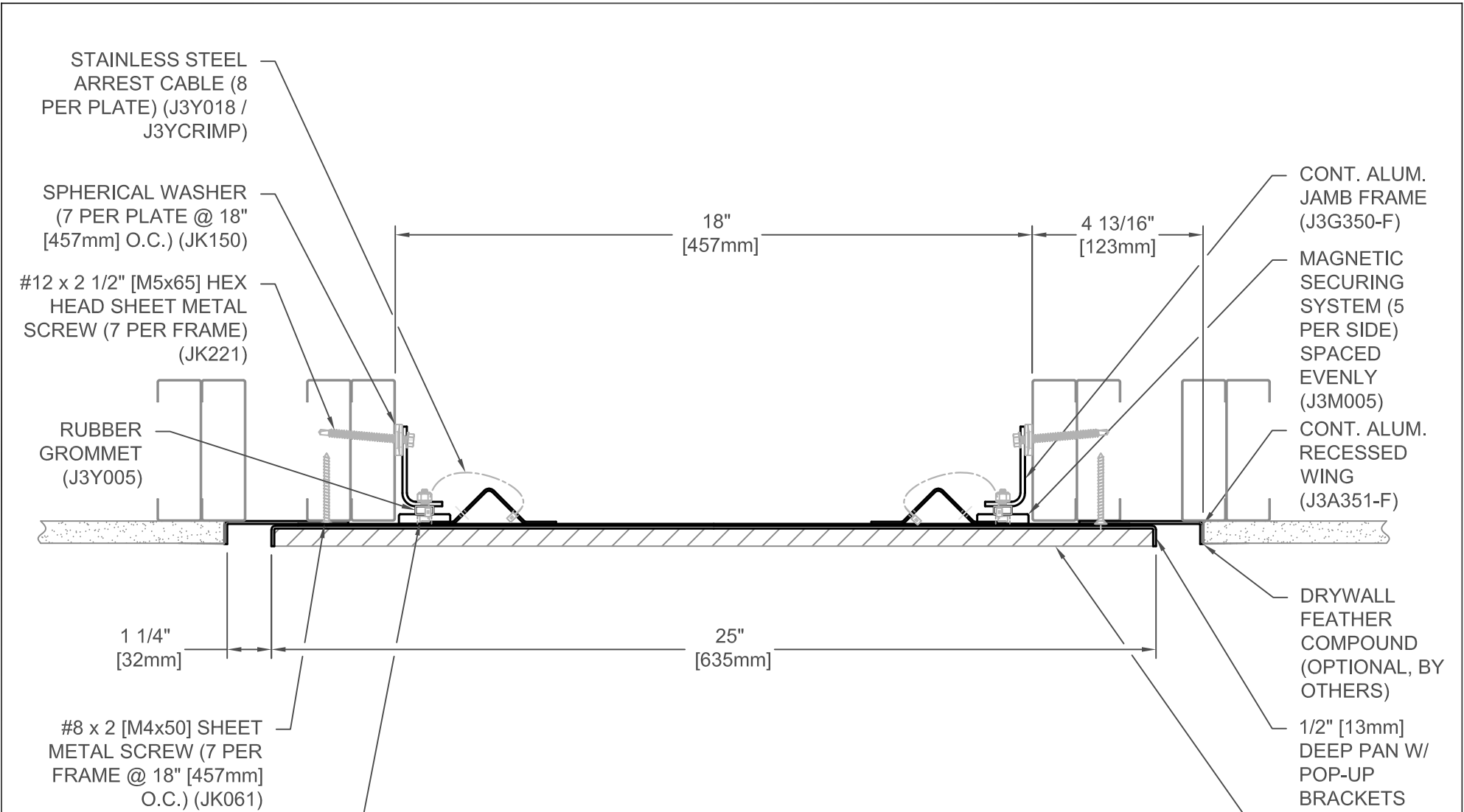

353-A24-450P

JOINT WIDTH		MOVEMENT			
		MINIMUM		MAXIMUM	
US	mm	US	mm	US	mm
18"	457	2 3/4"	70	36"	914

FINISH: MILL
PROJECT:
CUSTOMER:
LOCATION:

APPLICATION -
 CEILING/CEILING CONCEALED PAN EXPANSION JOINT SYSTEM-
 ACCEPTS VARIETY OF WALL FINISHES

DATE:	9/4/18
SCALE:	1:4
DOC:	CADJM.204/R2



For More Information Visit: Inprocorp.com

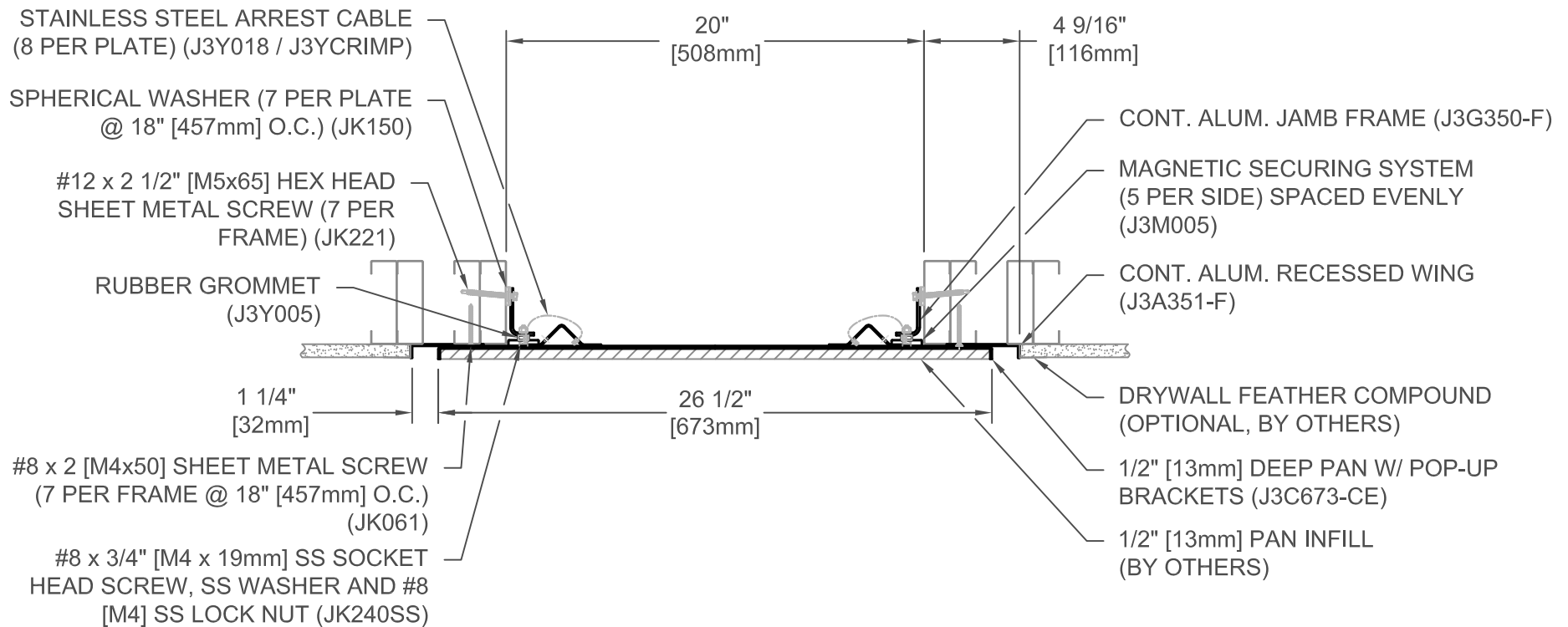

353-A24-500P

JOINT WIDTH		MOVEMENT			
		MINIMUM		MAXIMUM	
US	mm	US	mm	US	mm
20"	508	2 3/4"	70	40"	1016

FINISH: MILL
PROJECT:
CUSTOMER:
LOCATION:

APPLICATION -
 CEILING/CEILING CONCEALED PAN EXPANSION JOINT SYSTEM-
 ACCEPTS VARIETY OF WALL FINISHES

DATE:	9/4/18
SCALE:	1:8
DOC:	CADJM.204/R2



For More Information Visit: Inprocorp.com

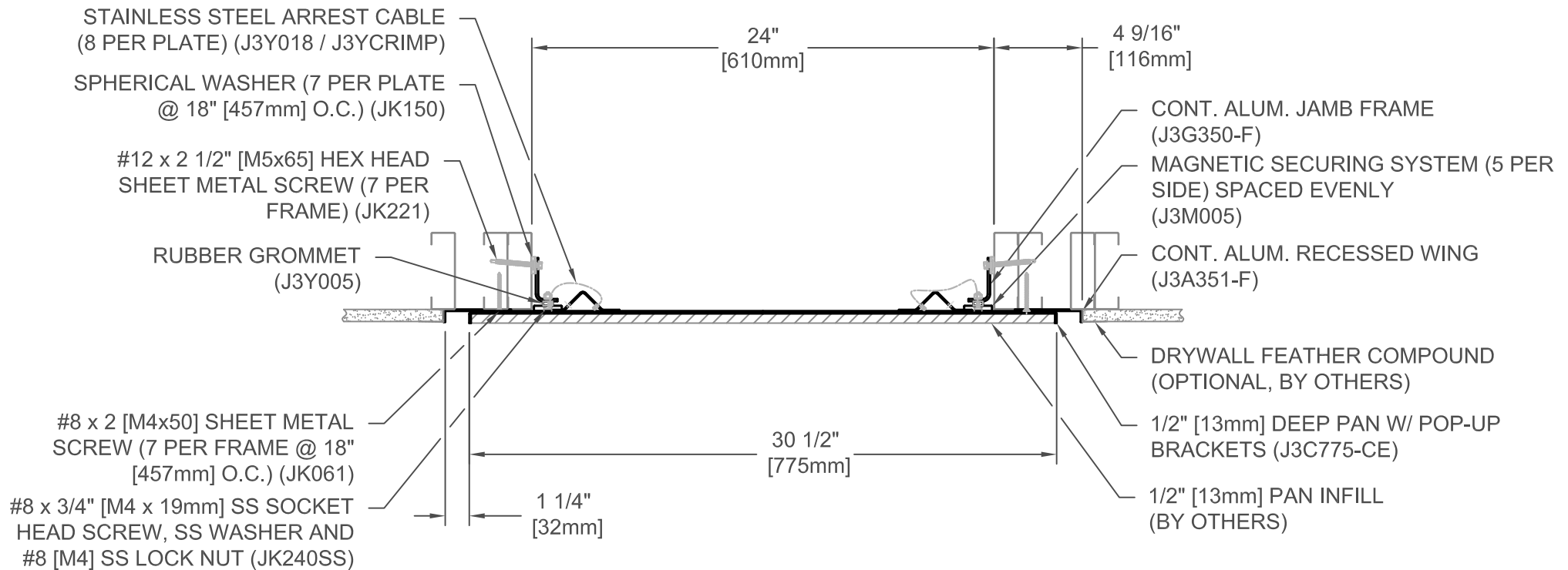

353-A24-600P

JOINT WIDTH		MOVEMENT			
		MINIMUM		MAXIMUM	
US	mm	US	mm	US	mm
24"	610	2 3/4"	70	48"	1219

FINISH: MILL
PROJECT:
CUSTOMER:
LOCATION:

APPLICATION -
 CEILING/CEILING CONCEALED PAN EXPANSION JOINT SYSTEM-
 ACCEPTS VARIETY OF WALL FINISHES

DATE:	9/4/18
SCALE:	1:8
DOC:	CADJM.204/R2

 For More Information Visit: Inprocorp.com