

353-A18-150P

JOINT WIDTH		MOVEMENT			
		MINIMUM		MAXIMUM	
US	mm	US	mm	US	mm
6"	152	2 3/4"	70	12"	305

FINISH: MILL
PROJECT:
CUSTOMER:
LOCATION:

APPLICATION -
 CEILING/WALL CONCEALED PAN EXPANSION JOINT SYSTEM-
 ACCEPTS VARIETY OF WALL FINISHES

DATE:	9/4/18
SCALE:	1:4
DOC:	CADJM.205/R2

STAINLESS STEEL ARREST
CABLE (8 PER PLATE)
(J3Y018 / J3YCRIMP)

SPHERICAL WASHER (7 PER
PLATE @ 18" [457mm] O.C.)
(JK150)

#12 x 2 1/2" [M5x65] HEX
HEAD SHEET METAL SCREW
(7 PER FRAME) (JK221)

#8 x 3/4" [M4 x 19mm] SS
SOCKET HEAD SCREW, SS
WASHER AND #8 [M4] SS
LOCK NUT (JK240SS)

RUBBER GROMMET (J3Y005)

1/2" [13mm] DEEP PAN W/
POP-UP BRACKETS
(J3C267-CE1)

1/2" [13mm] PAN INFILL
(BY OTHERS)

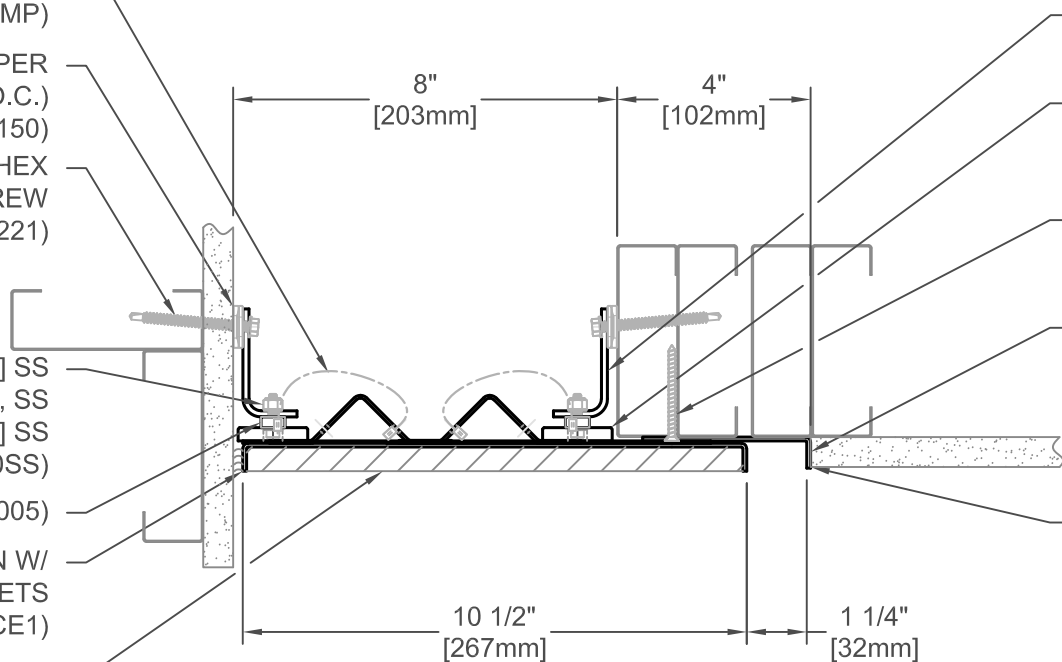

CONT. ALUM. JAMB FRAME
(J3G350-F)

MAGNETIC SECURING SYSTEM
(5 PER SIDE) SPACED EVENLY
(J3M005)

#8 x 2 [M4x50] SHEET METAL
SCREW (7 PER FRAME @ 18"
[457mm] O.C.) (JK061)

CONT. ALUM. RECESSED
WING (J3A351-F2)

DRYWALL FEATHER COMPOUND
(OPTIONAL, BY OTHERS)

353-A18-200P

JOINT WIDTH		MOVEMENT			
		MINIMUM		MAXIMUM	
US	mm	US	mm	US	mm
8"	203	2 3/4"	70	16"	406

FINISH: MILL
PROJECT:
CUSTOMER:
LOCATION:

APPLICATION -
CEILING/WALL CONCEALED PAN EXPANSION JOINT SYSTEM-
ACCEPTS VARIETY OF WALL FINISHES

DATE:	9/4/18
SCALE:	1:4
DOC:	CADJM.205/R2

inpro.

For More Information Visit: Inprocorp.com

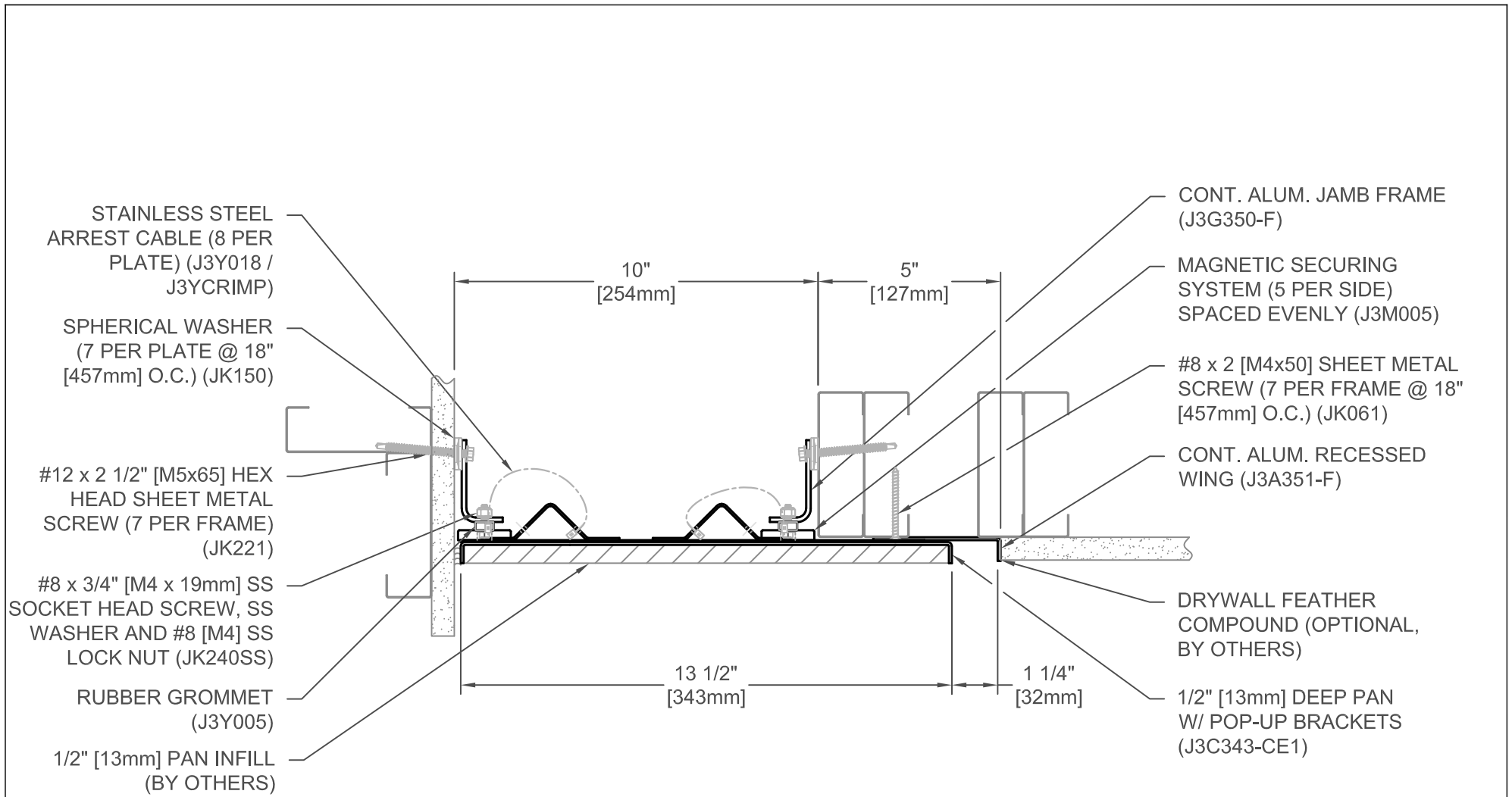

353-A18-250P

JOINT WIDTH		MOVEMENT			
		MINIMUM		MAXIMUM	
US	mm	US	mm	US	mm
10"	254	2 3/4"	70	20"	508

FINISH: MILL
PROJECT:
CUSTOMER:
LOCATION:

APPLICATION -
CEILING/WALL CONCEALED PAN EXPANSION JOINT SYSTEM-
ACCEPTS VARIETY OF WALL FINISHES

DATE:	9/4/18
SCALE:	1:4
DOC:	CADJM.205/R2

inpro.

For More Information Visit: Inprocorp.com

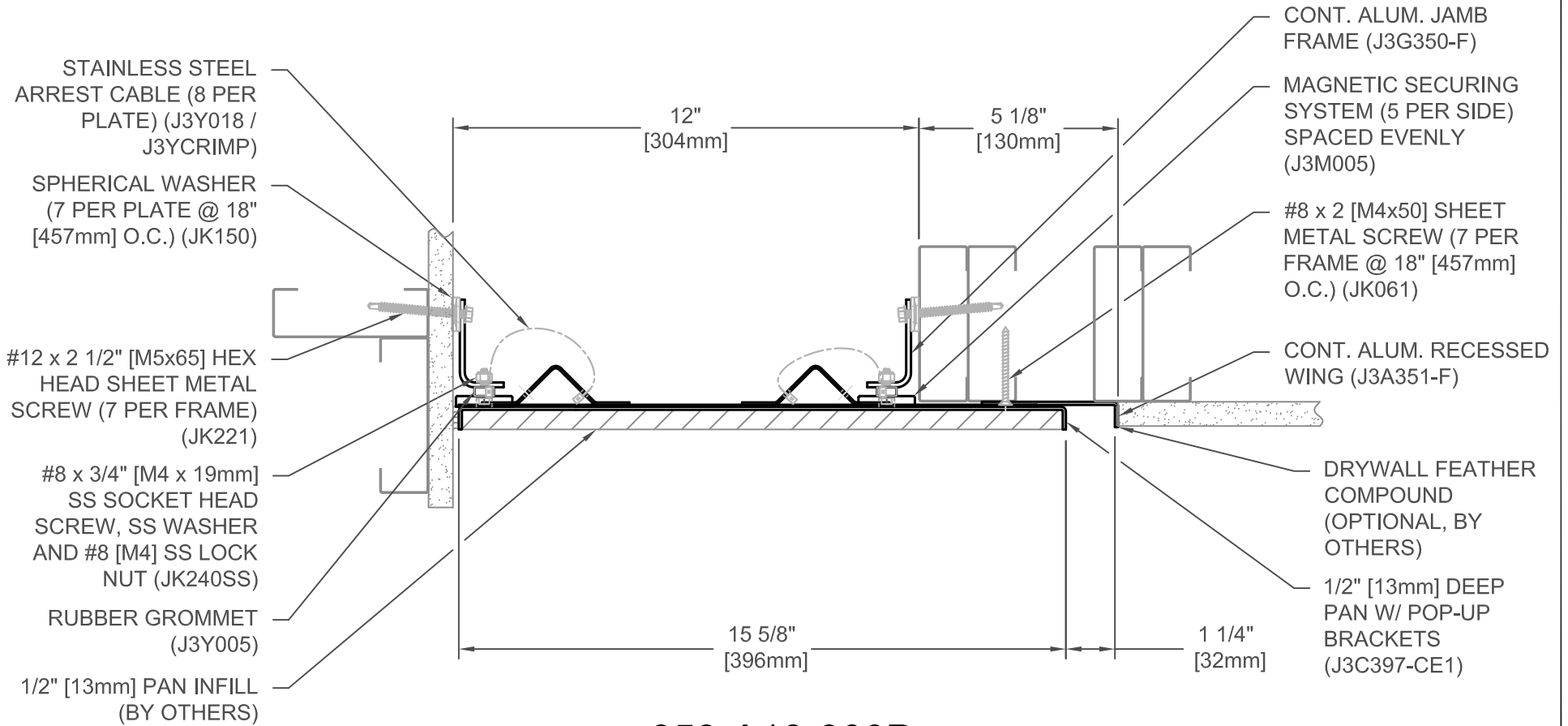

353-A18-300P

JOINT WIDTH		MOVEMENT			
		MINIMUM		MAXIMUM	
US	mm	US	mm	US	mm
12"	305	2 3/4"	70	24"	610

FINISH: MILL
PROJECT:
CUSTOMER:
LOCATION:

APPLICATION -
 CEILING/WALL CONCEALED PAN EXPANSION JOINT SYSTEM-
 ACCEPTS VARIETY OF WALL FINISHES

DATE:	9/4/18
SCALE:	1:4
DOC:	CADJM.205/R2



For More Information Visit: Inprocorp.com

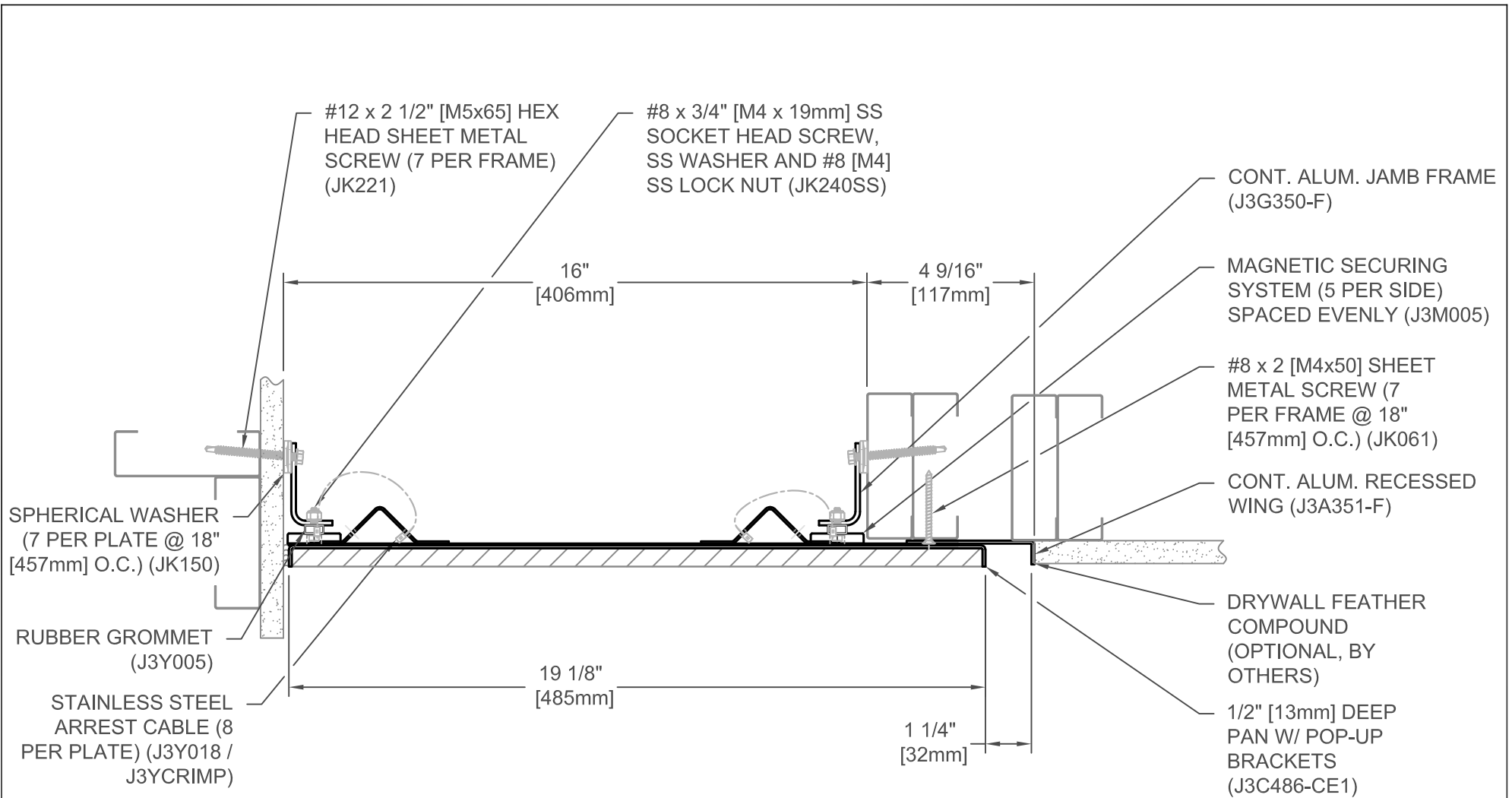

353-A18-400P

JOINT WIDTH		MOVEMENT			
		MINIMUM		MAXIMUM	
US	mm	US	mm	US	mm
16"	406	2 3/4"	70	32"	813

FINISH: MILL
PROJECT:
CUSTOMER:
LOCATION:

APPLICATION -
 CEILING/WALL CONCEALED PAN EXPANSION JOINT SYSTEM-
 ACCEPTS VARIETY OF WALL FINISHES

DATE:	9/4/18
SCALE:	1:4
DOC:	CADJM.205/R2

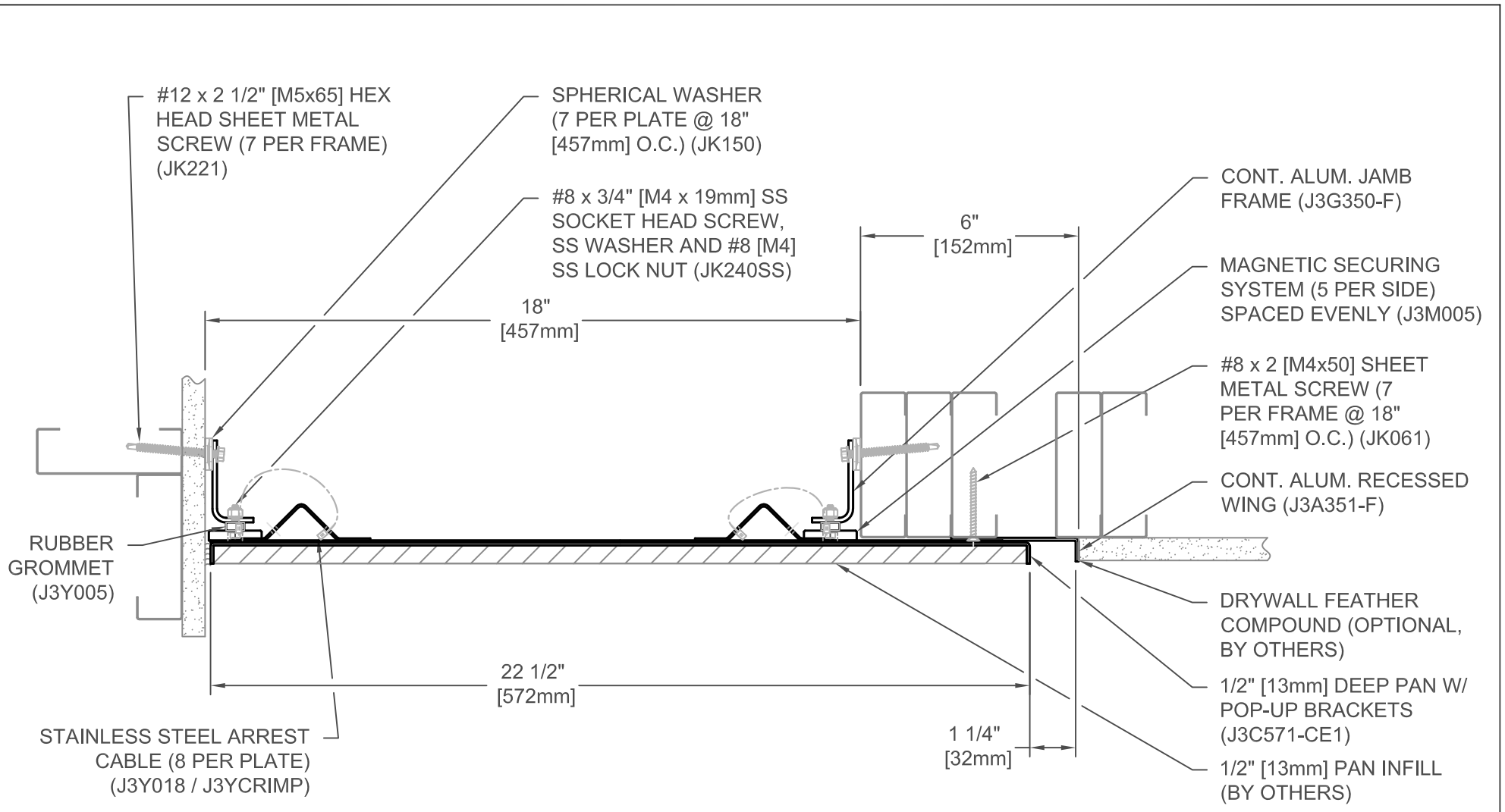

353-A18-450P

JOINT WIDTH		MOVEMENT			
		MINIMUM		MAXIMUM	
US	mm	US	mm	US	mm
18"	457	2 3/4"	70	36"	914

FINISH: MILL
PROJECT:
CUSTOMER:
LOCATION:

APPLICATION -
 CEILING/WALL CONCEALED PAN EXPANSION JOINT SYSTEM-
 ACCEPTS VARIETY OF WALL FINISHES

DATE:	9/4/18
SCALE:	1:4
DOC:	CADJM.205/R2



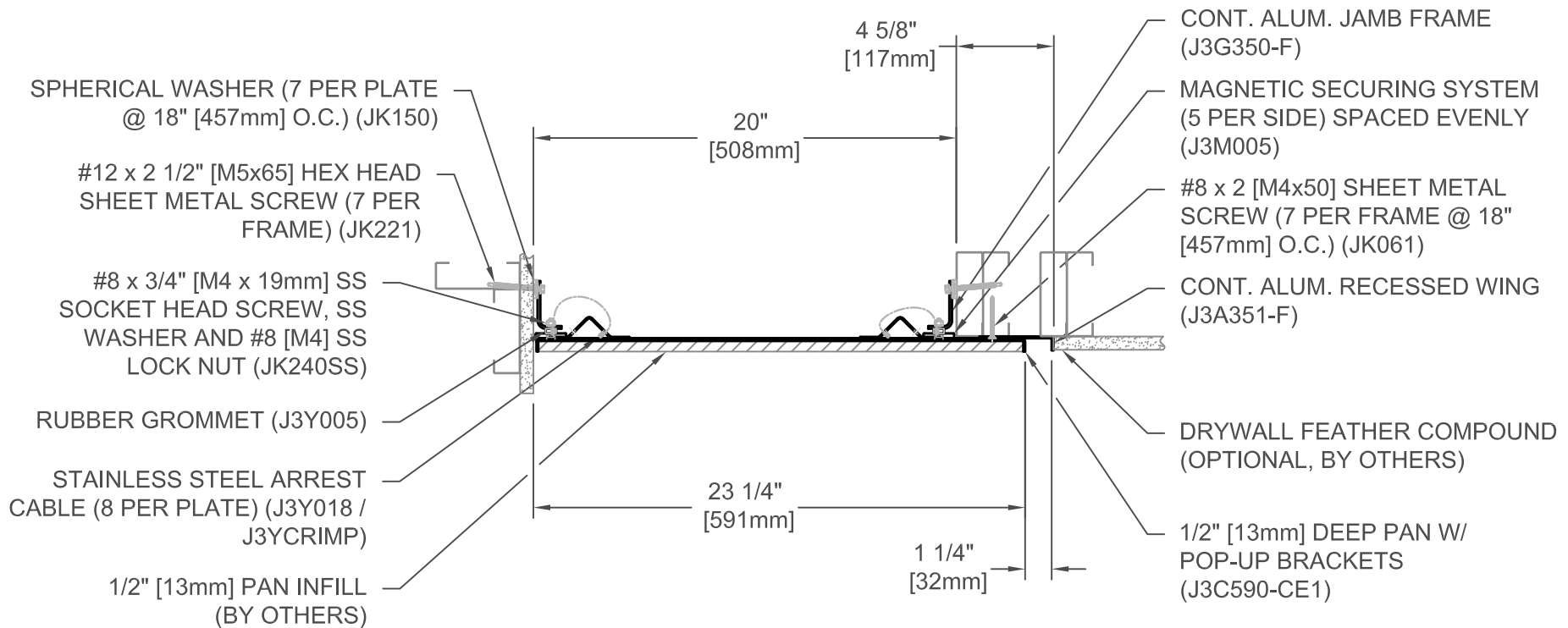

353-A18-500P

JOINT WIDTH		MOVEMENT			
		MINIMUM		MAXIMUM	
US	mm	US	mm	US	mm
20"	508	2 3/4"	70	40"	1016

FINISH: MILL
PROJECT:
CUSTOMER:
LOCATION:

APPLICATION -
 CEILING/WALL CONCEALED PAN EXPANSION JOINT SYSTEM-
 ACCEPTS VARIETY OF WALL FINISHES

DATE:	9/4/18
SCALE:	1:8
DOC:	CADJM.205/R2



For More Information Visit: Inprocorp.com

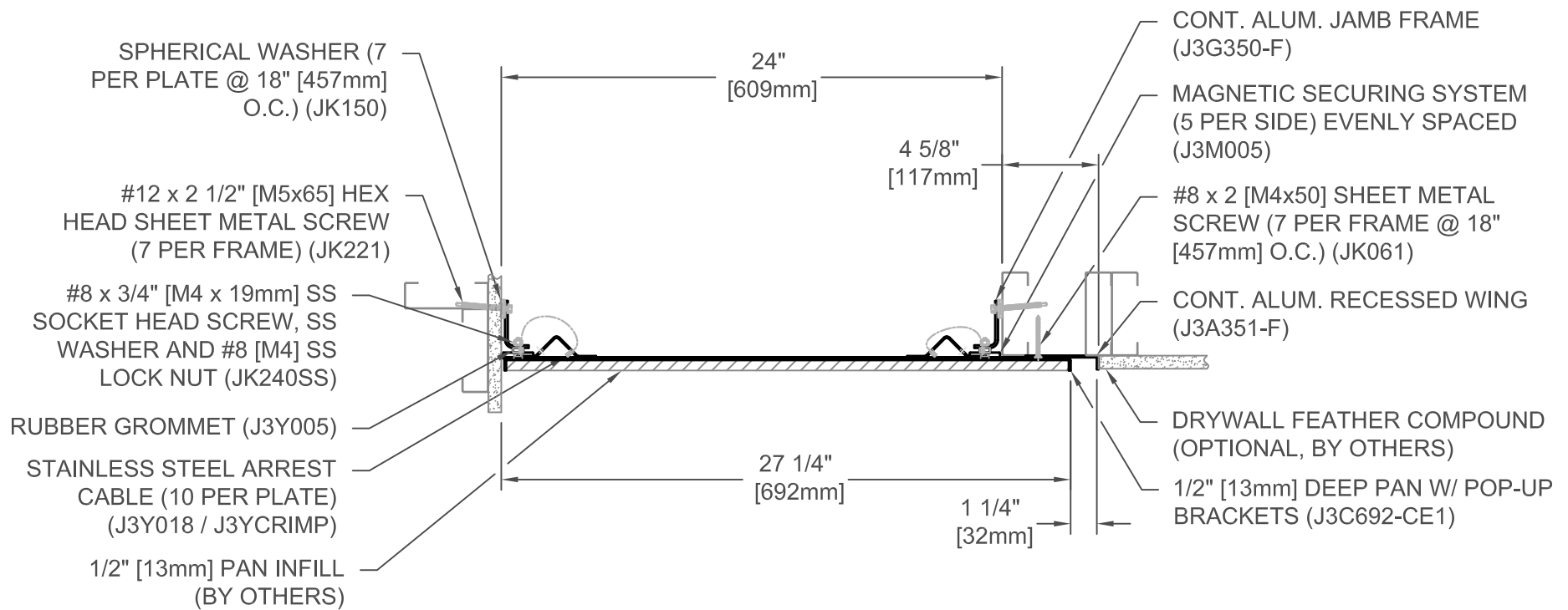

353-A18-600P

JOINT WIDTH		MOVEMENT			
		MINIMUM		MAXIMUM	
US	mm	US	mm	US	mm
24"	610	2 3/4"	70	48"	1219

FINISH: MILL
PROJECT:
CUSTOMER:
LOCATION:

APPLICATION -
 CEILING/WALL CONCEALED PAN EXPANSION JOINT SYSTEM-
 ACCEPTS VARIETY OF WALL FINISHES

DATE:	9/4/18
SCALE:	1:8
DOC:	CADJM.205/R2



For More Information Visit: Inprocorp.com