

353-A07-150P

JOINT WIDTH		MOVEMENT			
		MINIMUM		MAXIMUM	
US	mm	US	mm	US	mm
6"	152	2 3/4"	70	12"	305

FINISH: MILL
PROJECT:
CUSTOMER:
LOCATION:

APPLICATION -
WALL/WALL CONCEALED PAN EXPANSION JOINT SYSTEM- ACCEPTS
VARIETY OF WALL FINISHES

DATE:	9/4/18
SCALE:	1:4
DOC:	CADJM.200/R2

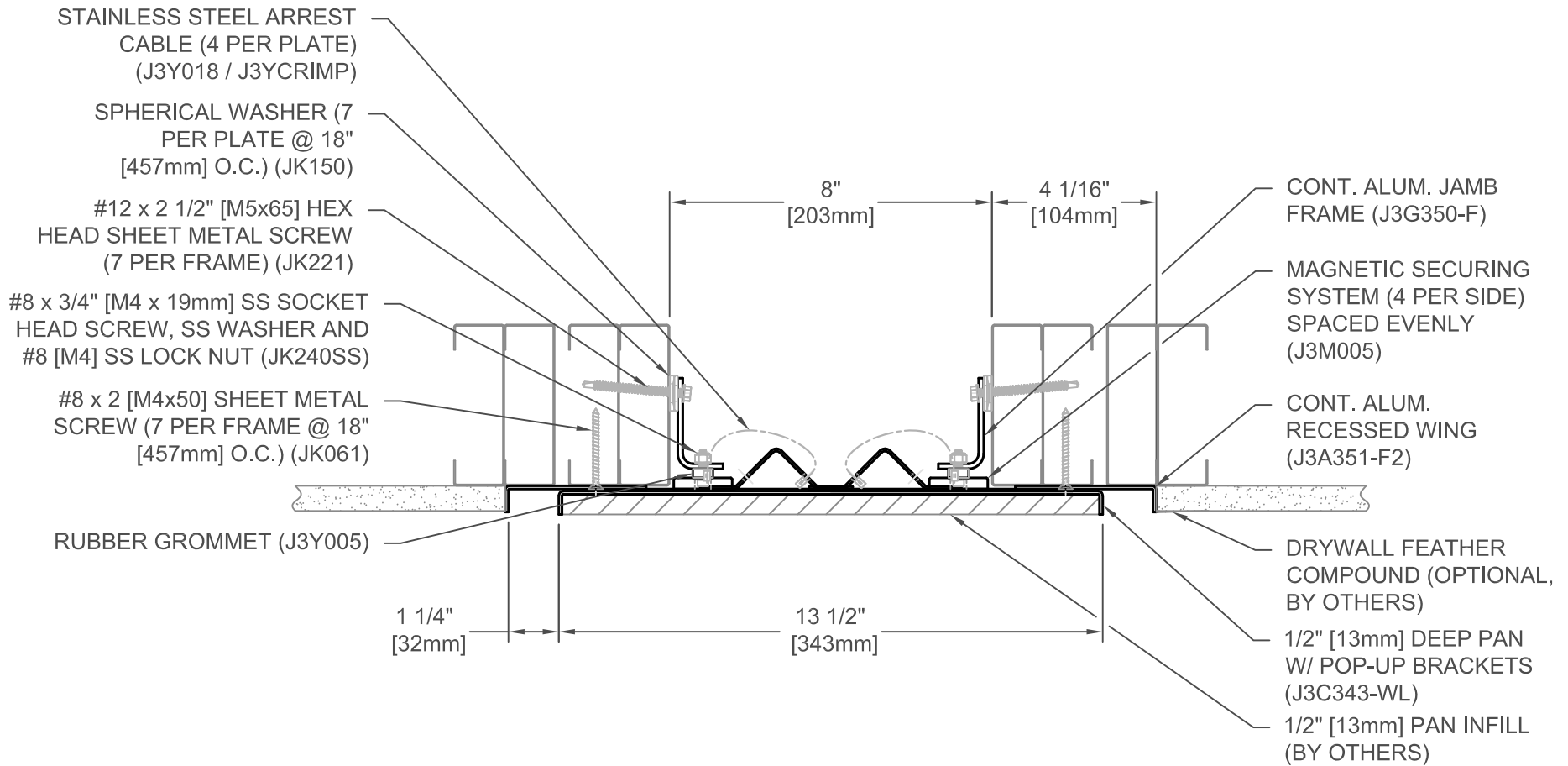

353-A07-200P

JOINT WIDTH		MOVEMENT			
		MINIMUM		MAXIMUM	
US	mm	US	mm	US	mm
8"	203	2 3/4"	70	16"	406

FINISH: MILL
PROJECT:
CUSTOMER:
LOCATION:

APPLICATION -
WALL/WALL CONCEALED PAN EXPANSION JOINT SYSTEM- ACCEPTS
VARIETY OF WALL FINISHES

DATE:	9/4/18
SCALE:	1:4
DOC:	CADJM.200/R2

inpro.
For More Information Visit: Inprocorp.com

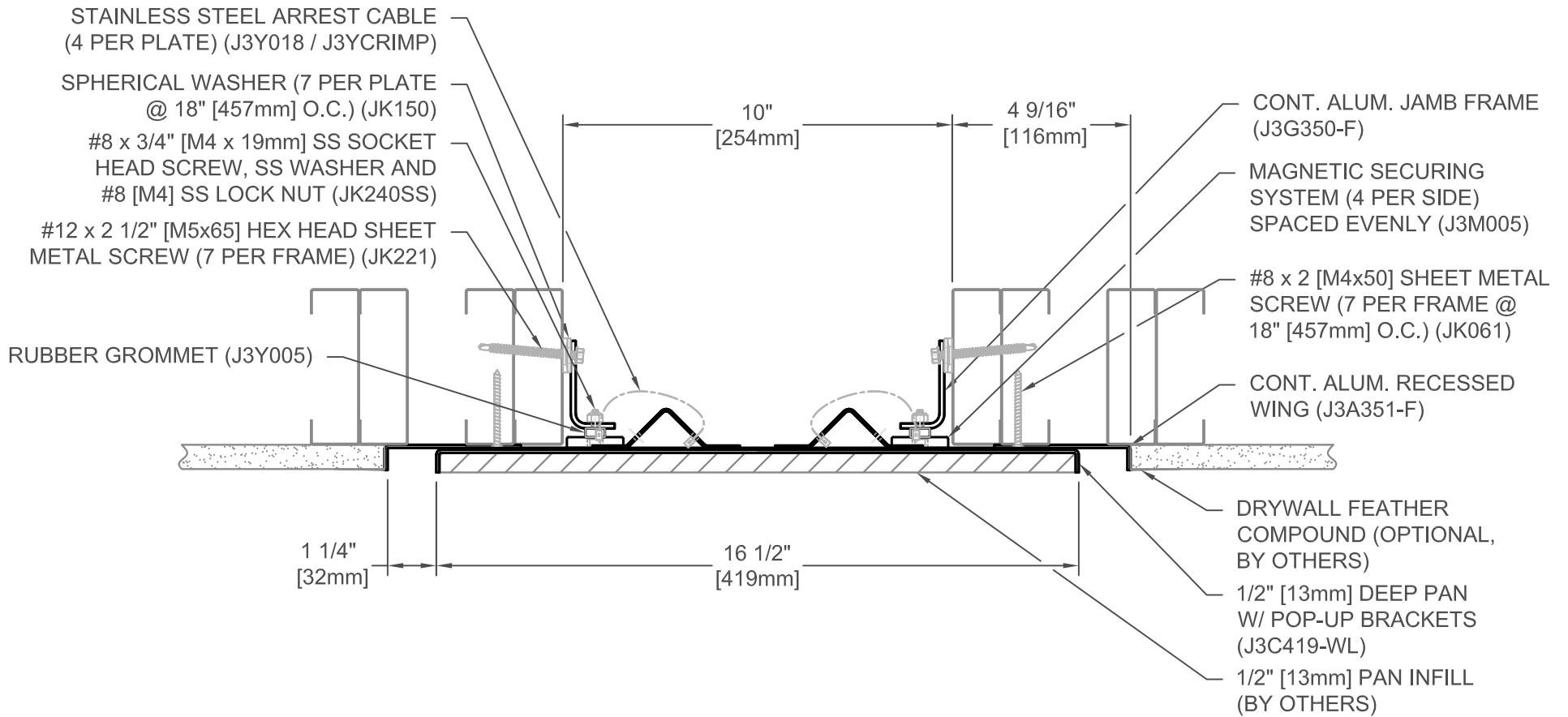

353-A07-250P

JOINT WIDTH		MOVEMENT			
		MINIMUM		MAXIMUM	
US	mm	US	mm	US	mm
10"	254	2 3/4"	70	20"	508

FINISH: MILL
PROJECT:
CUSTOMER:
LOCATION:

APPLICATION -
WALL/WALL CONCEALED PAN EXPANSION JOINT SYSTEM- ACCEPTS
VARIETY OF WALL FINISHES

DATE:	9/4/18
SCALE:	1:4
DOC:	CADJM.200/R2

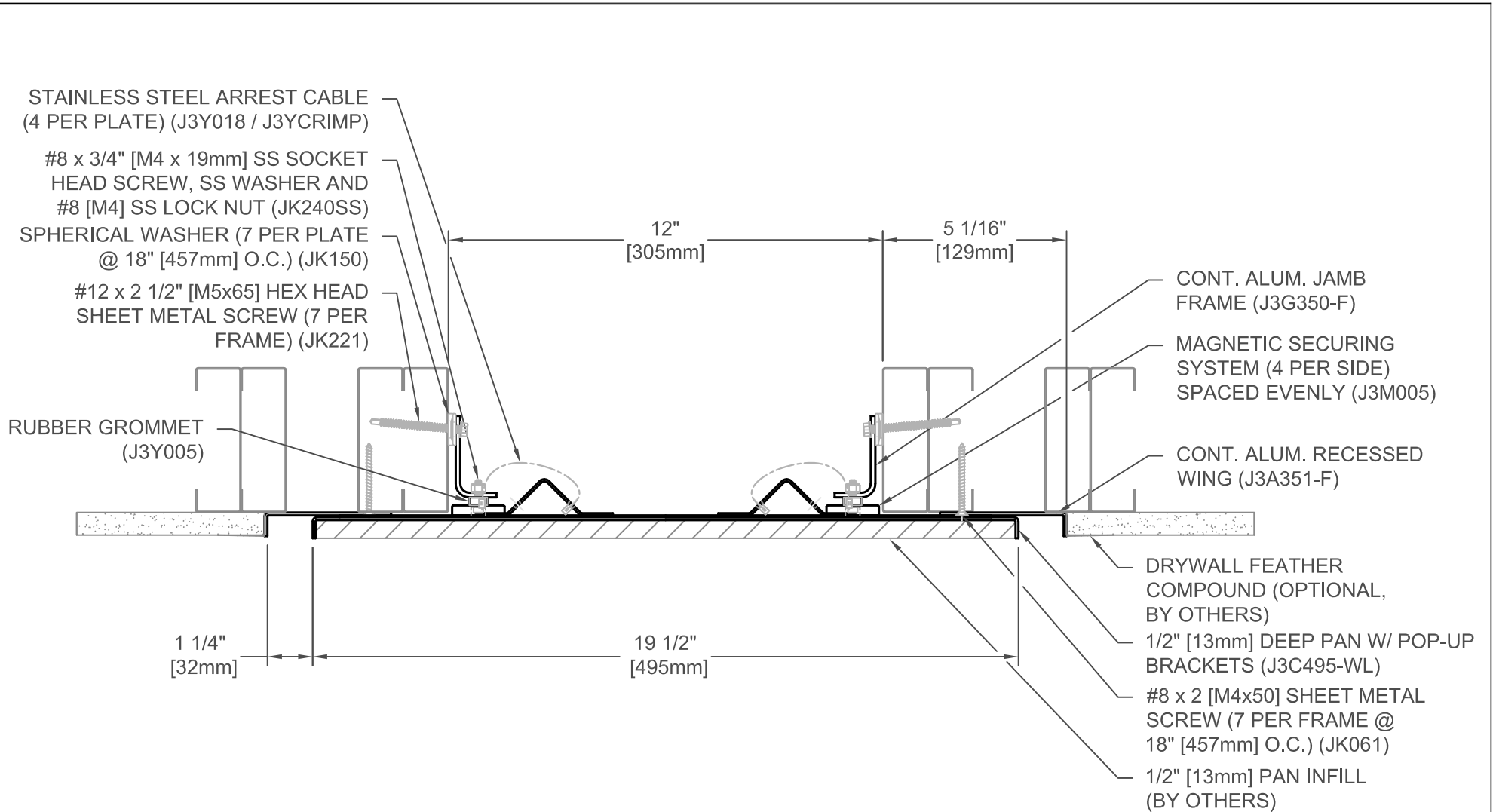

353-A07-300P

JOINT WIDTH		MOVEMENT			
		MINIMUM		MAXIMUM	
US	mm	US	mm	US	mm
12"	305	2 3/4"	70	24"	610

FINISH: MILL
PROJECT:
CUSTOMER:
LOCATION:

APPLICATION -
WALL/WALL CONCEALED PAN EXPANSION JOINT SYSTEM- ACCEPTS
VARIETY OF WALL FINISHES

DATE:	9/4/18
SCALE:	1:4
DOC:	CADJM.200/R2



For More Information Visit: Inprocorp.com

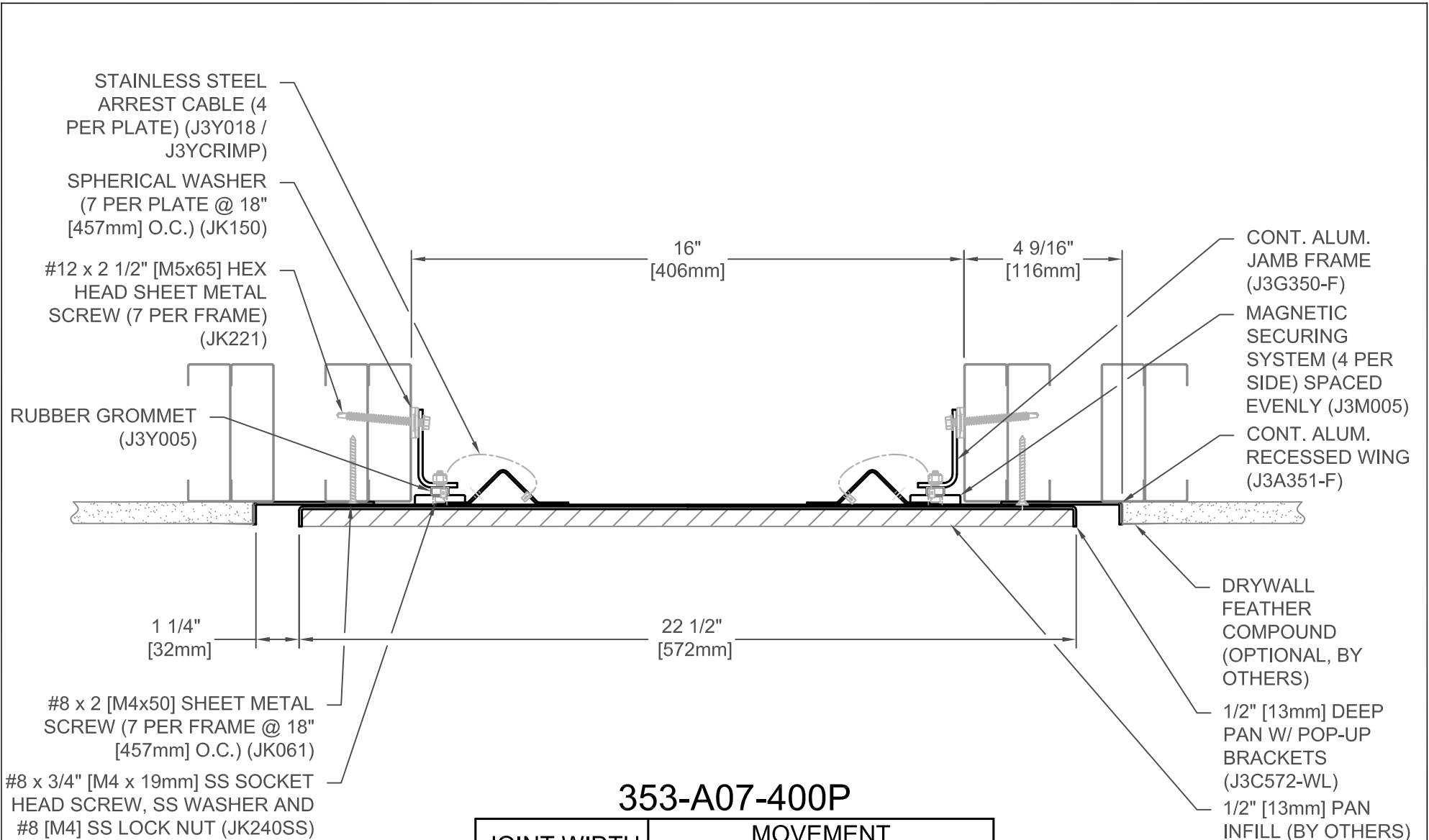

353-A07-400P

JOINT WIDTH		MOVEMENT			
		MINIMUM		MAXIMUM	
US	mm	US	mm	US	mm
16"	406	2 3/4"	70	32"	813

FINISH: MILL
PROJECT:
CUSTOMER:
LOCATION:

APPLICATION -
WALL/WALL CONCEALED PAN EXPANSION JOINT SYSTEM- ACCEPTS
VARIETY OF WALL FINISHES

DATE:	9/4/18
SCALE:	1:4
DOC:	CADJM.200/R2



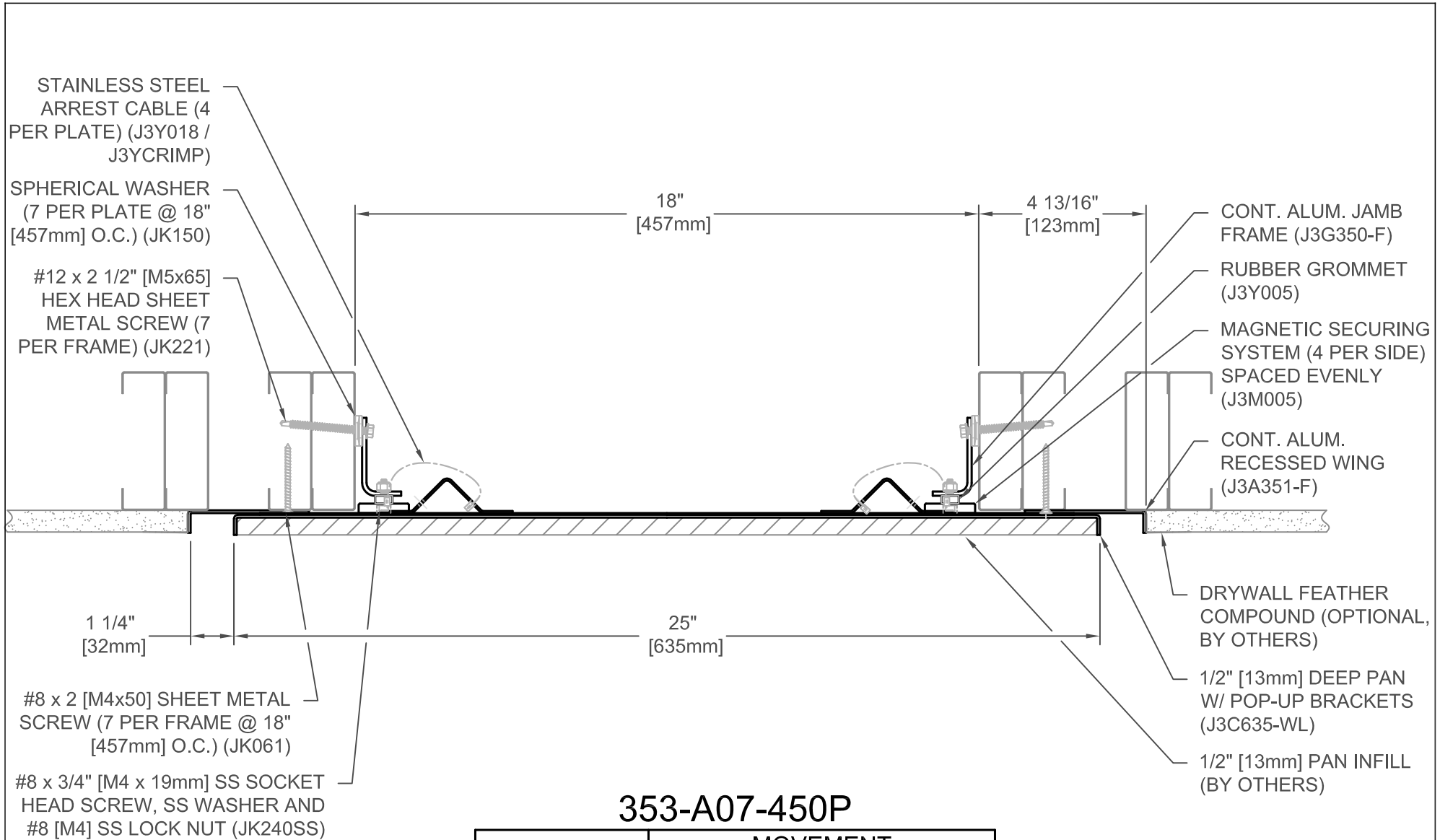

353-A07-450P

JOINT WIDTH		MOVEMENT			
		MINIMUM		MAXIMUM	
US	mm	US	mm	US	mm
18"	457	2 3/4"	70	36"	914

FINISH: MILL
PROJECT:
CUSTOMER:
LOCATION:

APPLICATION -
WALL/WALL CONCEALED PAN EXPANSION JOINT SYSTEM- ACCEPTS
VARIETY OF WALL FINISHES

DATE:	9/4/18
SCALE:	1:4
DOC:	CADJM.200/R2



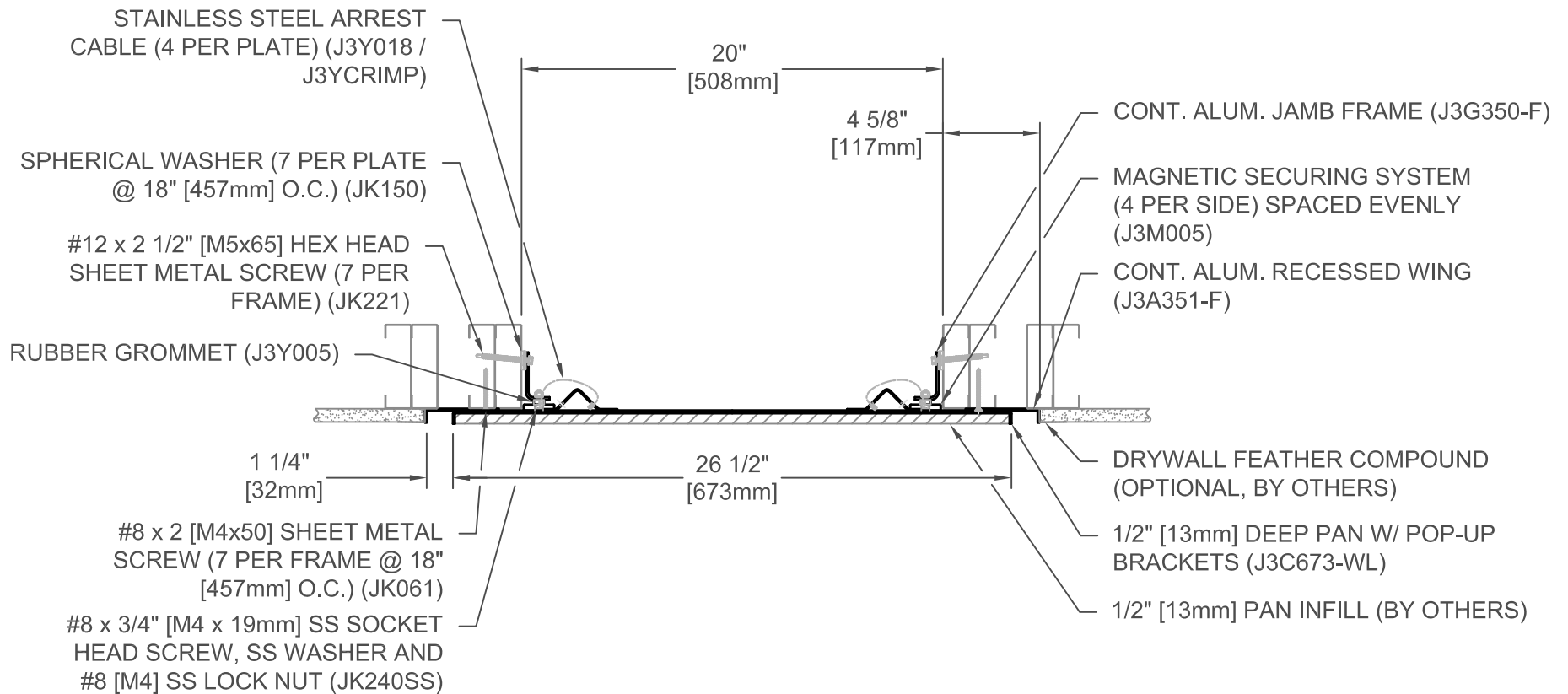

353-A07-500P

JOINT WIDTH		MOVEMENT			
		MINIMUM		MAXIMUM	
US	mm	US	mm	US	mm
20"	508	2 3/4"	70	40"	1016

FINISH: MILL
PROJECT:
CUSTOMER:
LOCATION:

APPLICATION -
WALL/WALL CONCEALED PAN EXPANSION JOINT SYSTEM- ACCEPTS
VARIETY OF WALL FINISHES

DATE:	9/4/18
SCALE:	1:8
DOC:	CADJM.200/R2

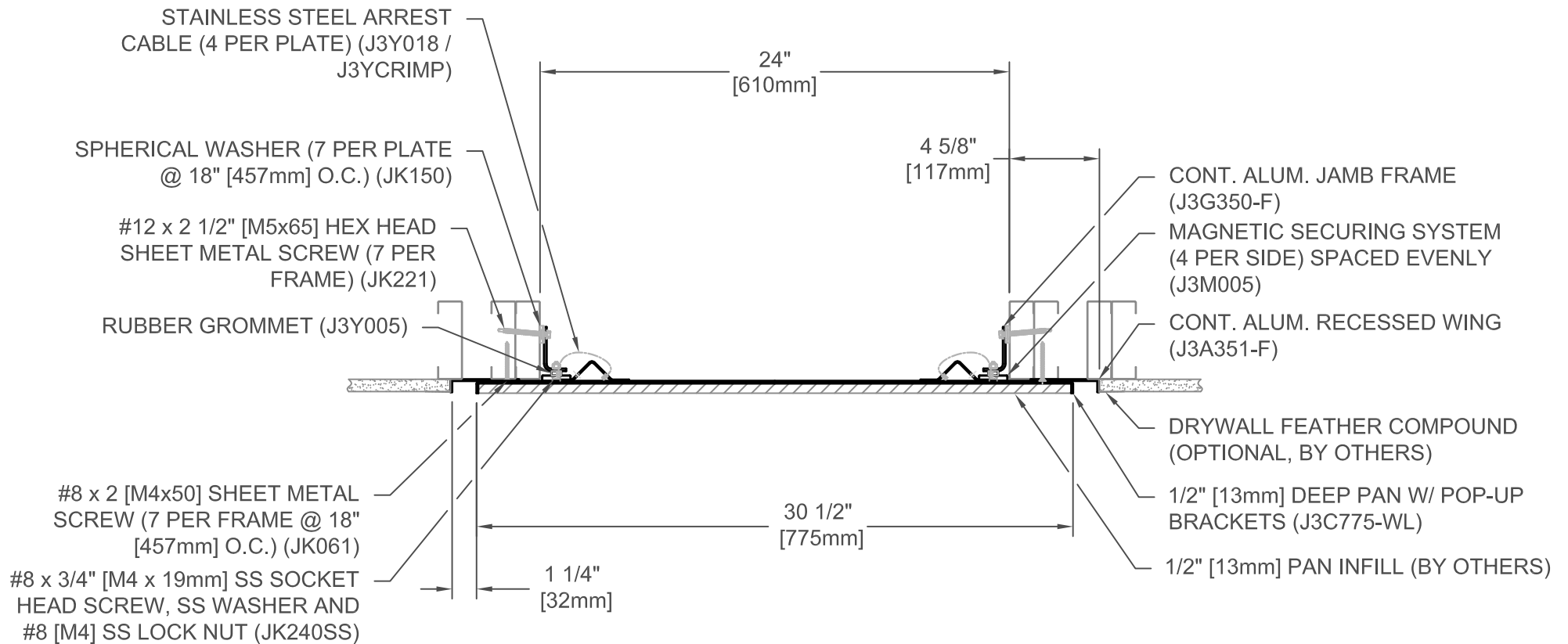

353-A07-600P

JOINT WIDTH		MOVEMENT			
		MINIMUM		MAXIMUM	
US	mm	US	mm	US	mm
24"	610	2 3/4"	70	48"	1219

FINISH: MILL
PROJECT:
CUSTOMER:
LOCATION:

APPLICATION -
WALL/WALL CONCEALED PAN EXPANSION JOINT SYSTEM- ACCEPTS
VARIETY OF WALL FINISHES

DATE:	9/4/18
SCALE:	1:8
DOC:	CADJM.200/R2

