

- 5/8" DRYWALL (BY OTHERS)
- TINNERMAN U-CLIP (7 PER FRAME @ 18" [457mm] O.C.) (JK090)
- CONT. ALUM. FRAME (J3A151)
- CONT. ALUM. MAIN FRAME COVER (J3G151)
- CONT. VINYL GASKET (J3D505)

- #8x2 [M4x50] SHEET METAL SCREW (7 PER FRAME @ 18" [457mm] O.C.) (JK061)
- CONT. ALUM. WALL ANGLE FRAME (J3A121)
- TINNERMAN U-CLIP (7 PER FRAME @ 18" O.C.) (JK090)
- CONT. SPRING STEEL CENTER PLATE (J3C111-F)

### 318-A09-050

JOINT WIDTH		MOVEMENT ±			
		HORIZONTAL		VERTICAL	
US	mm	US	mm	US	mm
2"	51	1"	25	1/2"	13

FINISH: CLEAR ANODIZED / STAINLESS 2B
PROJECT:
CUSTOMER:
LOCATION:

APPLICATION-  
GLIDE PLATE  
WALL/CORNER, CONDITION

DATE:	5-23-07
SCALE:	1:2
DOC:	CADJM.111/R1



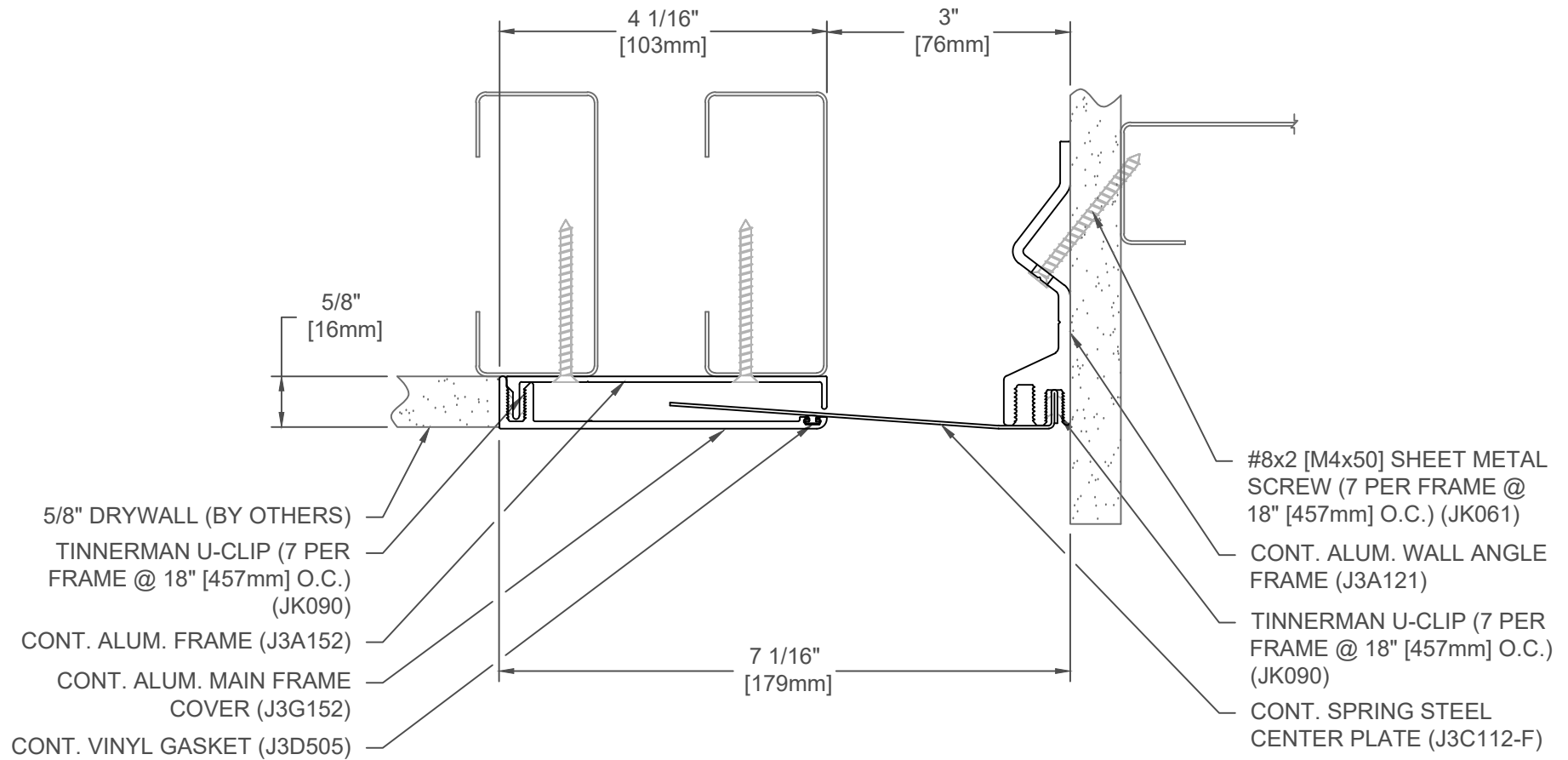

### 318-A09-075

JOINT WIDTH		MOVEMENT ±			
		HORIZONTAL		VERTICAL	
US	mm	US	mm	US	mm
3"	76	1 1/2"	38	3/4"	19

FINISH: CLEAR ANODIZED / STAINLESS 2B
PROJECT:
CUSTOMER:
LOCATION:

APPLICATION-  
GLIDE PLATE  
WALL/CORNER, CONDITION

DATE:	5-23-07
SCALE:	1:2
DOC:	CADJM.111/R1



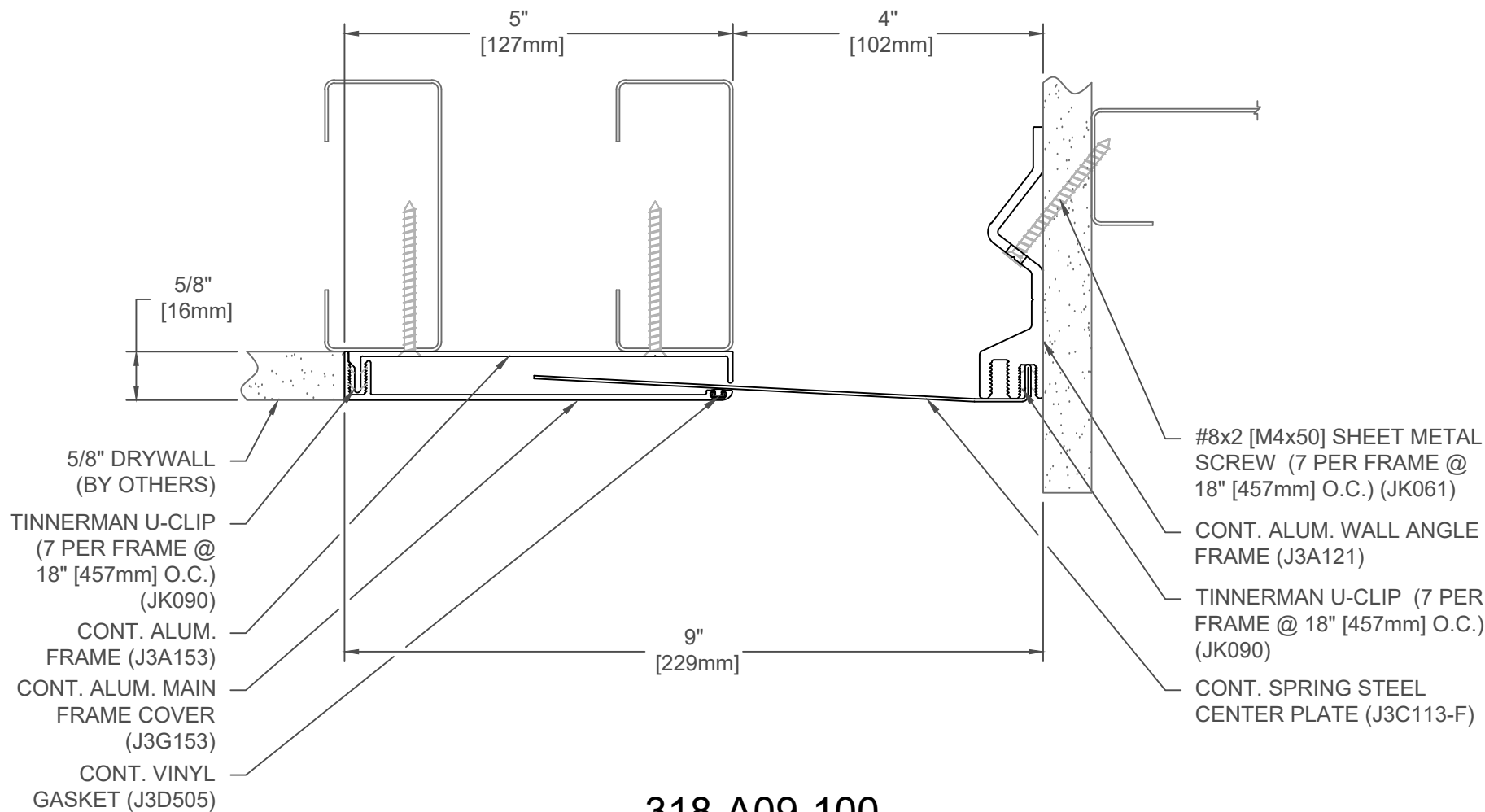

### 318-A09-100

JOINT WIDTH		MOVEMENT ±			
		HORIZONTAL		VERTICAL	
US	mm	US	mm	US	mm
4"	102	2"	51	1"	25

FINISH: CLEAR ANODIZED / STAINLESS 2B
PROJECT:
CUSTOMER:
LOCATION:

APPLICATION-  
GLIDE PLATE  
WALL/CORNER, CONDITION

DATE:	5-23-07
SCALE:	1:2
DOC:	CADJM.111/R1



For More Information Visit: [Inprocorp.com](http://Inprocorp.com)